



STATE OF MAINE  
BOARD OF ENVIRONMENTAL PROTECTION  
17 STATE HOUSE STATION  
AUGUSTA, ME 04333

**BOARD ORDER**

**IN THE MATTER OF**

NORDIC AQUAFARMS INC.	)	MAINE POLLUTANT DISCHARGE
BELFAST, WALDO COUNTY, MAINE	)	ELIMINATION SYSTEM PERMIT
LAND BASED AQUACULTURE	)	AND
ME0002771	)	WASTE DISCHARGE LICENSE
W009200-6F-A-N	)	<b>NEW</b>
		<b>APPROVAL</b>

In accordance with the applicable provisions of *Pollution Control*, 38 M.R.S. §§ 411 – 424-B, *Water Classification Program*, 38 M.R.S. §§ 464 – 470, and *Federal Water Pollution Control Act*, Title 33 U.S.C. § 1251, and applicable rules of the Department of Environmental Protection (Department), the Board of Environmental Protection (Board) has considered the application of NORDIC AQUAFARMS INC. (Nordic or permittee) for a new combination Maine Pollutant Discharge Elimination System (MEPDES) permit/Maine Waste Discharge License (WDL)(collectively permit) with its supportive data, agency review comments, public hearing record, intervenor and public comments and other related materials on file and FINDS THE FOLLOWING FACTS:

**APPLICATION SUMMARY**

On October 19, 2018, Nordic submitted an application to the Department for a new MEPDES permit/WDL for the monthly average discharge of 7.7 million gallons per day (MGD) of treated wastewater associated with a land-based recirculating aquaculture system (RAS) to Belfast Bay, Class SB, in Belfast and Northport, Maine. Nordic also submitted and the Department accepted applications for Site Law and Natural Resources Protection Act permits and a Chapter 115 Air Emissions License. The permittee proposes to rear Atlantic salmon from the egg life stage to market size fish weighing 10-12 pounds. At full production, the facility will be able to produce approximately 30,000 metric tons or 66 million pounds of fish per year. The permittee proposes to construct a fish processing facility (head-on, gutted) on-site.

Nordic proposes to construct the facility in two phases. Phase I will consist of infrastructure connection to the site, earth moving, construction of the smolt facility, the water and the waste water treatment systems, three (3) grow out modules, a processing facility and the intake and discharge pipes. The permittee estimates that Phase I will take 12-15 months to complete. Following the completion of Phase I construction, Phase II construction will consist of constructing three (3) grow-out modules and the visitor center. The permittee estimates Phase II construction will take another 12 months.

### **APPLICATION SUMMARY (cont'd)**

At the request of Nordic, on June 20, 2019, the Board voted to assume jurisdiction of the MEPDES permit/WDL and other applications. Between February 11 and February 14, 2020, the Board held an adjudicatory hearing in Belfast on Nordic's applications.

On May 20, 2020, the Board held a deliberative session on the MEPDES permit/WDL application and other applications.

On August 13, 2020, the Board made the Department staff's draft recommended decision on MEPDES permit #ME0002771/Maine Waste Discharge License #W009200-6F-A-N available for a formal 30-day public comment period. On September 24, 2020, the Board of Environmental Protection, via its Twenty-First Procedural Order, granted certain commenters an extension of the comment period until October 5, 2020 to amend the relevant portion of their previous submittals, or file an additional comment, to correct or augment their comments regarding nutrient removal percentages<sup>1</sup>. All comments received on the draft recommended Board Order were reviewed and considered by staff of the Department and the Board. A response to comments section can be found in the attached Fact Sheet.

### **PERMIT SUMMARY**

This permit establishes:

1. Technology-based numeric limitations for flow, biochemical oxygen demand (BOD), total suspended solids (TSS) and pH;
2. A requirement to seasonally (May – October) monitor the effluent for total phosphorus, total ammonia, total kjeldahl nitrogen, nitrate + nitrite nitrogen;
3. A monthly average water quality-based mass limitation for total nitrogen;
4. A requirement for the permittee to conduct a dye study to more accurately determine the mixing characteristics of the treated effluent discharge from the facility with the receiving water;
5. A requirement to conduct seasonal (May – October) ambient water quality monitoring at five (5) stations in Belfast Bay and deploy a minimum of two Acoustic Doppler Current Profilers (ADCPs) to gather more information on the currents and the behavior of tidal exchanges in the near-field and far-field;
6. A requirement for the facility to develop and maintain an Operations & Maintenance (O&M) Plan for the production facility and the wastewater treatment facility;

---

<sup>1</sup>These commenters were Nordic; Upstream Watch; Northport Village Corporation; Jeffrey R. Mabee, Judith B. Grace, and Lobstering Representatives, and Friends of the Harriet L. Hartley Conservation Area; and Kristina Debye.

**PERMIT SUMMARY (cont'd)**

7. A requirement to limit the use of antibiotics, fungicides, bactericides, parasiticides and other chemical compounds;
8. A requirement for the facility to develop and maintain a Containment Management System (CMS) to prevent escape of fish from the facility; and
9. Best practicable treatment (BPT) and General Reporting requirements consistent with National Effluent Guidelines (NEG) found at 40 Code of Federal Regulations (CFR), Part 451 – *Concentrated Aquatic Animal Production Point Source Category*.
10. A requirement for the permittee to meet with the Department's permitting and compliance inspection staff 90 days prior to commencement of operations to review the permit limitations, monitoring requirements and reporting requirements.

**CONCLUSIONS AND FINDINGS**

BASED on the findings in the attached Fact Sheet dated August 13, 2020, and revised on November 19, 2020, subject to the Conditions listed below, the BOARD makes the following CONCLUSIONS AND FINDINGS:

1. The discharge, either by itself or in combination with other discharges, will not lower the quality of any classified body of water below its classification.
2. The discharge, either by itself or in combination with other discharges, will not lower the quality of any unclassified body of water below the classification which the Department expects to adopt in accordance with State law.<sup>2</sup>
3. The provisions of the State's antidegradation policy, *Classification of Maine waters*, 38 M.R.S. § 464(4)(F), will be met, in that:
  - (a) Existing in-stream water uses and the level of water quality necessary to protect and maintain those existing uses will be maintained and protected;
  - (b) Where high quality waters of the State constitute an outstanding national resource, that water quality will be maintained and protected;<sup>3</sup>

---

<sup>2</sup> The Board finds the receiving waters for this discharge are classified as SB. See 38 M.R.S. § 469; pages 10 and 11 of the Fact Sheet. The Board is not aware of any unclassified water bodies that will be affected by this discharge.

<sup>3</sup> The Board finds the receiving waters for this discharge do not constitute an outstanding national resource. See 38 M.R.S. § 465-B.

**CONCLUSIONS AND FINDINGS (cont'd)**

- (c) Where the standards of classification of the receiving waterbody are not met, the discharge will not cause or contribute to the failure of the waterbody to meet the standards of classification;<sup>4</sup>
  - (d) Where the actual quality of any classified receiving waterbody exceeds the minimum standards of the next highest classification that higher water quality will be maintained and protected;<sup>5</sup> and
  - (e) Where a discharge will result in lowering the existing water quality of any waterbody, the Department has made the finding, following opportunity for public participation, that this action is necessary to achieve important economic or social benefits to the State.<sup>6</sup>
4. The discharge will be subject to effluent limitations that require application of best practicable treatment as defined in 38 M.R.S. § 414-A(1)(D).
  5. Pursuant to the Board's interpretation of the Department's Chapter 2 regarding title, right or interest (TRI), the Board finds that the applicant has made a sufficient showing of TRI to develop the property as proposed. As the Department found in its June 13, 2019 acceptance letter, the deeds and other submissions, including Nordic's options to purchase, and the analysis of the chain of title remain unchanged and remain a sufficient showing for the Board to take action on the application.

The basis for the above conclusions and findings is contained in the attached Fact Sheet.

---

<sup>4</sup> The Board finds the receiving waters for this discharge meet the standards of classification.

<sup>5</sup> The Board finds the receiving waters for this discharge do not exceed the minimum standards of the next highest classification.

<sup>6</sup> As explained on pages 36 and 37 of the Fact Sheet, the Board finds Nordic's discharge, as conditioned, will not result in the lowering of existing water quality. The additional requirements of this subparagraph have therefore not been triggered.

**ACTION**

THEREFORE, the BOARD APPROVES the application of NORDIC AQUAFARMS INC. to discharge a monthly average flow of 7.7 MGD of treated wastewater associated with a land-based RAS to Belfast Bay, Class SB in Belfast and Northport, Maine, subject to the attached conditions and all applicable standards and regulations:

1. “*Maine Pollutant Discharge Elimination System Permit Standard Conditions Applicable to All Permits*,” revised July 1, 2002, copy attached.
2. The attached Special Conditions, including any effluent limitations and monitoring requirements.
3. This permit becomes effective upon the date of signature below and expires at midnight five (5) years after that date. If a renewal application is timely submitted and accepted as complete for processing prior to the expiration of this permit, the terms and conditions of this permit and all subsequent modifications and minor revisions thereto remain in effect until a final Department decision on the renewal application becomes effective. [*Maine Administrative Procedure Act*, 5 M.R.S. § 10002 and *Rules Concerning the Processing of Applications and Other Administrative Matters*, 06-096 CMR 2(21)(A) (last amended June 9, 2018)].

PLEASE NOTE ATTACHED SHEET FOR GUIDANCE ON APPEAL PROCEDURES DONE  
AND DATED AT AUGUSTA, MAINE, THIS 19th DAY OF NOVEMBER 2020. BOARD OF  
ENVIRONMENTAL PROTECTION

BY:   
Robert Duchesne, Presiding Officer, Board of Environmental Protection

Date of initial receipt of application October 19, 2018

Date of application acceptance November 9, 2018

**SPECIAL CONDITIONS**

**A. EFFLUENT LIMITATIONS AND MONITORING REQUIREMENTS**

1. The permittee is authorized to discharge treated **wastewater associated with a land-based RAS from Outfall #001A** to Belfast Bay. Such discharges are limited and must be monitored by the permittee as specified below:<sup>(1)</sup>

Effluent Characteristic					Minimum Monitoring Requirements	
	Monthly Average	Daily Maximum	Monthly Average	Daily Maximum	Measurement Frequency	Sample Type
Flow <i>[50050]</i>	7.7 MGD <i>[03]</i>	---	---	---	Continuous <i>[99/99]</i>	Meter <i>[MR]</i>
Biochemical Oxygen Demand <sup>(5)</sup> (BOD <sub>5</sub> ) <i>[00310]</i>	1,926 lbs./day <i>[26]</i>	3,211 lbs./day <i>[26]</i>	30 mg/L <i>[19]</i>	50 mg/L <i>[19]</i>	3/Week <i>[03/07]</i>	Composite <sup>(2)</sup> <i>[24]</i>
Total Suspended Solids(TSS) <sup>(5)</sup> <i>[00530]</i>	1,926 lbs./day <i>[26]</i>	3,211 lbs./day <i>[26]</i>	30 mg/L <i>[19]</i>	50 mg/L <i>[19]</i>	3/Week <i>[03/07]</i>	Composite <sup>(2)</sup> <i>[24]</i>
Total Kjeldahl Nitrogen (as N) <i>[00625]</i> ( <b>May – Oct</b> )	Report lbs/day <sub><i>[26]</i></sub>	Report lbs/day <sub><i>[26]</i></sub>	Report mg/L <sub><i>[19]</i></sub>	Report mg/L <sub><i>[19]</i></sub>	1/Week <sub><i>[01/07]</i></sub>	Composite <sup>(2)</sup> <sub><i>[24]</i></sub>
Nitrate + Nitrite Nitrogen (as N) <i>[00630]</i> ( <b>May – Oct</b> )	Report lbs/day <sub><i>[26]</i></sub>	Report lbs/day <sub><i>[26]</i></sub>	Report mg/L <sub><i>[19]</i></sub>	Report mg/L <sub><i>[19]</i></sub>	1/Week <sub><i>[01/07]</i></sub>	Composite <sup>(2)</sup> <sub><i>[24]</i></sub>
Total Nitrogen (as N) <sup>(3,5)</sup> <i>[00600]</i> ( <b>May – Oct</b> )	1,348 lbs/day <sub><i>[26]</i></sub>	Report lbs/day <sub><i>[26]</i></sub>	Report mg/L <sub><i>[19]</i></sub>	Report mg/L <sub><i>[19]</i></sub>	1/Week <sub><i>[01/07]</i></sub>	Composite <sup>(2)</sup> <sub><i>[24]</i></sub>
Fish on Hand <i>[45604]</i>	---	Report Metric Tons <sub><i>[41]</i></sub>	---	---	1/Month <sub><i>[01/30]</i></sub>	Calculated <sub><i>[CA]</i></sub>
Total Phosphorus <sup>(4)</sup> <i>[00665]</i> ( <b>May – Oct</b> )	Report lbs/day <sub><i>[26]</i></sub>	Report lbs/day <sub><i>[26]</i></sub>	Report mg/L <sub><i>[19]</i></sub>	Report mg/L <sub><i>[19]</i></sub>	1/Week <sub><i>[01/07]</i></sub>	Composite <sup>(2)</sup> <sub><i>[24]</i></sub>
Total Ammonia (as N) <i>[00610]</i> ( <b>May – Oct</b> )	Report lbs/day <sub><i>[26]</i></sub>	Report lbs/day <sub><i>[26]</i></sub>	Report mg/L <sub><i>[19]</i></sub>	Report mg/L <sub><i>[19]</i></sub>	1/Week <sub><i>[01/07]</i></sub>	Grab <sub><i>[GR]</i></sub>
Temperature <i>[00011]</i> ( <b>May – Oct</b> ) ( <b>Nov – April</b> )	---	---	---	64°F <sub><i>[15]</i></sub> 64°F <sub><i>[15]</i></sub>	1/Day <sub><i>[01/01]</i></sub> 1/Week <sub><i>[01/07]</i></sub>	Measure <sub><i>[MS]</i></sub> Measure <sub><i>[MS]</i></sub>
pH (Std. Units) <i>[00400]</i>	---	---	---	6.0-9.0 <sub><i>[12]</i></sub>	3/Week <sub><i>[03/07]</i></sub>	Grab <sub><i>[GR]</i></sub>

## SPECIAL CONDITIONS

### A. EFFLUENT LIMITATIONS AND MONITORING REQUIREMENTS (cont'd)

#### Footnotes

1. **Sampling** – All effluent monitoring must be conducted following the last treatment unit prior to discharging to the receiving water. All monitoring must be conducted so as to be representative of end-of-pipe effluent characteristics. Any change in sampling location must be approved by the Department in writing. The permittee must conduct sampling and analysis in accordance with: a) methods approved by 40 Code of Federal Regulations (CFR) Part 136; b) alternative methods approved by the Department in accordance with the procedures in 40 CFR Part 136; or c) as otherwise specified by the Department. Samples that are sent out for analysis must be analyzed by a laboratory certified by the State of Maine's Department of Health and Human Services for wastewater. Samples that are sent to a laboratory operated by a waste discharge facility licensed pursuant to *Waste discharge licenses*, 38 M.R.S. § 413, are subject to the provisions and restrictions of *Maine Comprehensive and Limited Environmental Laboratory Certification Rules*, 10-144 CMR 263 (effective date April 1, 2010). If the permittee monitors any pollutant more frequently than required by the permit using test procedures approved under 40 CFR Part 136 or as specified in this permit, the results of this monitoring must be included in the calculation and reporting of the data submitted in the Discharge Monitoring Report (DMR).
2. **Composite sample** means a sample consisting of a minimum of eight grab samples collected at equal intervals during a 24-hour period (or a lesser period as specified in Special Condition A on monitoring and reporting) and combined proportional to the flow over that same time period.
3. **Total nitrogen (as N) – Monthly** – The permittee is required to report the monthly average and daily maximum mass and concentrations for each month (May – October) of each year by adding the total kjeldahl nitrogen values to the nitrate + nitrite nitrogen values for each sampling event. See **Attachment A** of this permit for *Protocol for Nitrogen Sample Collection and Analysis for Waste Water Effluent*.
4. **Total phosphorus** – See **Attachment B** of this permit for *Protocol for Total Phosphorus Sample Collection and Analysis for Waste Water and Receiving Water Monitoring Required by Permits*.
5. **BOD, TSS and Total nitrogen** - The monthly average and daily maximum limitations for biochemical oxygen demand, total suspended solids and total nitrogen will be subject to a statistical evaluation at the end of the term of this permit to assist the Department in establishing best practicable treatment standards for the RAS industry.

## **SPECIAL CONDITIONS**

### **B. NARRATIVE EFFLUENT LIMITATIONS**

1. The permittee must not discharge effluent that contains a visible oil sheen, foam or floating solids at any time which would impair the uses designated for the classification of the receiving waters.
2. The permittee must not discharge effluent that contains materials in concentrations or combinations which are hazardous or toxic to aquatic life, or which would impair the uses designated for the classification of the receiving waters.
3. The discharge must not impart visible discoloration, taste, turbidity, toxicity, radioactivity or other properties in the receiving waters which would impair the uses designated for the classification of the receiving waters.
4. The permittee must not discharge effluent that lowers the quality of any classified body of water below such classification or lowers the existing quality of any body of water if the existing quality is higher than the classification.

### **C. AUTHORIZED DISCHARGES**

The permittee is authorized to discharge only in accordance with: 1) the permittee's General Application for Waste Discharge Permit, accepted for processing on November 9, 2018; 2) the terms and conditions of this permit; 3) only from Outfall #001A; and 4) only after receiving a final Land-Based Aquaculture License from the Maine Department of Marine Resources. Discharges of wastewater from any other point source are not authorized under this permit and must be reported in accordance with Standard Condition D(1)(f), *Twenty-four-hour reporting*, of this permit.

### **D. NOTIFICATION REQUIREMENT**

In accordance with Standard Condition D, the permittee must notify the Department of the following:

1. Any substantial change in the volume or character of pollutants being introduced into the wastewater collection and treatment system.
2. For the purposes of this section, adequate notice must include information on:
  - a. The quality and quantity of wastewater introduced to the wastewater collection and treatment system; and
  - b. Any anticipated change in the quality and quantity of the wastewater to be discharged from the treatment system.



## **SPECIAL CONDITIONS**

### **E. MONITORING AND REPORTING**

#### Electronic Reporting

*NPDES Electronic Reporting*, 40 CFR 127, requires MEPDES permit holders to submit monitoring results obtained during the previous month on an electronic discharge monitoring report to the regulatory agency utilizing the United States Environmental Protection Agency (USEPA) electronic system.

Electronic Discharge Monitoring Reports (DMRs) submitted using the USEPA NetDMR system, must be:

1. Submitted by a facility authorized signatory; and
2. Submitted no later than **midnight on the 15<sup>th</sup> day of the month** following the completed reporting period.

Documentation submitted in support of the electronic DMR may be attached to the electronic DMR. Toxics reporting must be done using the DEP Toxsheet reporting form. An electronic copy of the Toxsheet reporting document must be submitted to the Department compliance inspector as an attachment to an email. In addition, a hardcopy form of this sheet must be signed and submitted to the compliance inspector, or a copy attached to the NetDMR submittal will suffice. Documentation submitted electronically to the Department in support of the electronic DMR must be submitted no later than midnight on the 15<sup>th</sup> day of the month following the completed reporting period.

### **F. DYE STUDY**

**Within 12 months of the effective date of this permit**, the permittee must submit a plan to the Department for review and approval that includes a scope of work and schedule to conduct a dye study to confirm the accuracy of the analysis of the mixing characteristics of the effluent being discharged with the receiving water.

**Within 6 months of the facility being capable of discharging 7.7 MGD**, the permittee must conduct a dye study to assess in practice the mixing characteristics of the treated effluent and the receiving water. The dye study must be conducted in July or August and at multiple tidal stages.

**Within 6 months of completion of the dye study**, the permittee must submit a report to the Department that characterizes the mixing conditions in the receiving water and depicts the radial propagation of measured dilution factors associated with the discharge, to the point where the dye concentration is below the instrument detection level.

## **SPECIAL CONDITIONS**

### **G. AMBIENT WATER QUALITY MONITORING**

**On or before March 1, 2021**, the permittee must submit an ambient water quality monitoring plan to the Department for review and approval, to monitor five (5) sampling stations established by the Department. The stations to be monitored are BB02, PB01, PB02, PB03, and PB04. See **Attachment F** of the Fact Sheet of this permit for a map depicting the locations of the monitoring sites. The proposed monitoring plan must conform with a Department approved Quality Assurance Project Plan (QAPP). All sampling and analysis must be conducted by: a) methods approved by 40 Code of Federal Regulations (CFR) Part 136, b) alternative methods approved by the Department in accordance with the procedures in 40 CFR Part 136, or c) as otherwise specified by the Department. As part of the parameter specific monitoring plan, the permittee must submit a monitoring plan to the Department for review and approval, utilizing a minimum of two (2) Acoustic Doppler Current Profilers (ADCPs) to gather more information on the currents and the behavior of tidal exchanges in the near field and far-field.

**Beginning May 1, 2021**, the permittee must commence ambient monitoring at the five (5) designated sites established by the Department at a frequency of approximately every three (3) weeks between May 1<sup>st</sup> and October 31<sup>st</sup> of each year. Each monitoring event must be conducted during a four (4) hour sampling window on the second half of an ebb or flood tide. Minimum parameters to be monitored via a sonde are temperature, salinity, pH, dissolved oxygen, chlorophyll *a*, and turbidity. Minimum parameters to be monitored via grab samples are total phosphorus, total kjeldahl nitrogen and nitrate + nitrite nitrogen. In addition to the parameter specific ambient water quality monitoring, the permittee must deploy the ADCPs at the approved designated sites established by the Department.

**On or before December 31<sup>st</sup> of each year**, the permittee must submit a report to the Department summarizing the data collected from the ambient water quality monitoring plans and report any trends or anomalies with the data.

### **H. OPERATION & MAINTENANCE PLAN**

**Within 6 months after commencement of the initial operations (eggs on-site)**, the permittee must submit a written Operation & Maintenance (O&M) Plan for the facility to the Department for review and comment. The plan must provide a systematic approach by which the permittee must at all times properly operate and maintain all facilities and systems of treatment and control (and related appurtenances) which are installed or used by the permittee to achieve compliance with the conditions of this permit.

## SPECIAL CONDITIONS

### H. OPERATION & MAINTENANCE PLAN (cont'd)

An acceptable O&M plan must ensure the following items are adequately addressed:

1. Solids Control
  - a. Methods and practices to ensure efficient feed management and feeding strategies that limit feed input to the minimum amount reasonably necessary to achieve production goals and sustain targeted rates of aquatic animal growth in order to minimize potential discharges to waters of the State.
  - b. In order to minimize the discharge of accumulated solids from the solids processing system and production systems, identify and implement procedures for routine cleaning of rearing units and any settling tanks, and procedures to minimize any discharge of accumulated solids during the inventorying, grading, and harvesting of aquatic animals in the production system.
  - c. Procedure for removal and disposal of mortalities.
2. Materials Storage
  - a. Ensure proper storage of drugs<sup>1</sup>, pesticides<sup>2</sup>, feed, chemicals and any petroleum and/or hazardous waste products in a manner designed to prevent spills that may result in the discharge of drugs, pesticides, or feed to waters of the State.
  - b. Implement procedures for properly containing, cleaning, and disposing of any spilled material that has the potential to enter waters of the State.
3. Structural Maintenance
  - a. Inspect the production system and the wastewater treatment system on a routine basis in order to identify and promptly repair any damage.
  - b. Conduct regular maintenance of the production system and the wastewater treatment system in order to ensure that they are properly functioning.

---

<sup>1</sup> **Drug.** “Drug” means any substance defined as a drug in section 201(g)(1) of the *Federal Food, Drug and Cosmetic Act* [21 U.S.C. § 321].

<sup>2</sup> **Pesticide.** “Pesticide” means any substance defined as a “pesticide” in section 2(u) of the *Federal Insecticide, Fungicide, and Rodenticide Act* [7 U.S.C. § 136 (u)].

## **SPECIAL CONDITIONS**

### **H. OPERATION & MAINTENANCE PLAN (cont'd)**

4. Recordkeeping
  - a. Maintain records for fish rearing units documenting the feed amounts and estimates of the numbers and weight of fish.
  - b. Maintain records that document the frequency of cleaning, inspections, repairs and maintenance.
  - c. Maintain records that document drug/pesticide/other compound use as indicated under Special Condition I, Disease Control.
  - d. Carry out all necessary MEPDES Licensing and Compliance related activities, and maintain associated documentation for a minimum of 3 years.
5. Training
  - a. In order to ensure the proper clean-up and disposal of spilled material adequately, train all relevant personnel in spill prevention and spill response.
  - b. Appropriately qualified managerial and operational staff shall be available and trained in the proper operation, maintenance, and upkeep of the Recirculating Aquaculture System, along with any related production and wastewater treatment systems, including training in feeding procedures and proper use of equipment to prevent unauthorized discharges.
6. Waste Water Operations
  - a. Provide a flow chart for the wastewater treatment process, the sludge and solids dewatering and removal process, and effluent discharge system.
  - b. Identify and develop operational and maintenance standard operating procedures for the treatment system components used to treat clean water, sludge water from cleaning mechanical filters, sludge water from backflushing biological treatment filters, and other wastewaters, as applicable:
    - (1) Belt/drum filters and thickeners;
    - (2) Use of flocculants/coagulants;
    - (3) Clarifiers/settling tanks;
    - (4) Fish exclusion barriers;

## **SPECIAL CONDITIONS**

### **H. OPERATION & MAINTENANCE PLAN (cont'd)**

- (5) Centrifuges;
- (6) UV disinfection/sterilization;
- (7) Chemical storage and disposal;
- (8) Intake/outfall maintenance;
- (9) Other

Define each of the following operator responsibilities:

- (1) Operations Manager qualifications and duties;
- (2) Staff duties;
- (3) Sample collection and analysis;
- (4) Regulatory reporting:
  - a. Discharge monitoring reports
  - b. Spill/release reports;
- (5) Any other operator responsibilities not listed.

**By December 31 of each year, or within 90 days of any process changes or minor equipment upgrades,** the permittee must evaluate and modify the O&M Plan including site plan(s) and schematic(s) for the wastewater treatment facility to ensure that it is up to date. The O&M Plan must be kept on-site at all times and made available to Department and USEPA personnel upon request.

**Within 90 days of completion of new and or substantial upgrades of the wastewater treatment facility,** the permittee must submit the updated O&M Plan to their Department inspector for review and comment.

## SPECIAL CONDITIONS

### I. DISEASE CONTROL

The permittee must comply with Maine Department of Inland Fisheries and Wildlife (MDIFW) (freshwater facilities) and Maine Department of Marine Resources MDMR (salmon & marine facilities) fish health laws (12 MRS, § 6071 and 12 MRS, §§10051, 10105, 12507 and 12509, as amended). The cited laws include requirements for notification to the appropriate agency within 24-hours of pathogen detection. In addition to the requirements of the MDIFW and MDMR rules, **the permittee shall notify the Department in writing within 24 hours following pathogen detection**, with information on the disease/pathogen, necessary control measures, and the contact information for the veterinarian(s) involved.

1. **General requirements.** All chemicals used at the facility must be applied in compliance with federal labeling restrictions and in compliance with applicable statute, Board of Pesticides Control rules and best management practices (BMPs). In accordance with Special Condition D of this permit, the permittee must notify the Department of any substantial change in the volume or character of pollutants being introduced into the wastewater collection and treatment system.
2. **FDA-approved drugs.** All drugs used for disease prevention or control must be approved or authorized by the U.S. Food and Drug Administration (FDA), and all applications must comply with applicable FDA requirements and shall only be administered in accordance with label instructions.
  - a. Drugs identified in the permittee's application: A list of drugs, chemicals and other compounds proposed for use at the permittee's facility during the term of the permit was provided by the permittee in its October 19, 2018, General Application for Waste Discharge Permit.
  - b. Preventative treatments: The discharge of any approved drug administered as a preventative measure is not authorized by this permit, unless the following conditions are met: the drug must be approved by FDA, and the treatment and route of administration must be consistent with the drug's intended use and according to label instructions. FDA approved drugs in the permittee's October 19, 2018 application are:
    1. Formalin (Parasite-S)
    2. Terramycin® 200 (oxytetracycline dehydrate)
    3. Aquaflor® (florfenicol)
    4. Romet ®30/Romet®TC (sulfadimethoxine/ormetoprim)
    5. Halamid Aqua® (Chloramine-T)
    6. Finquel®/Tricane-S (Tricaine methanesulfonate)
    7. Ovadine® (PVP Iodine)
    8. Potassium permanagante
    9. Hydrogen peroxide

## SPECIAL CONDITIONS

### I. DISEASE CONTROL (cont'd)

- c. Drugs not identified in the permittee's application: When the need to treat or control diseases requires the use of an FDA-approved drug not identified in the application, the permittee must notify the Department orally or by electronic mail prior to initial use of the drug.
  1. The notification must include a description of the drug, its intended purpose, the method of application, the amount, the concentration, the duration of the use, and information on aquatic toxicity.
  2. **Within seven (7) days of the initial notification**, the permittee must submit a written report that includes all of the information outlined in Section I.2(c)(1) above.
  3. The Department may require submission of an application for permit modification, including public notice requirements, if the drug is to be used for more than a 30-consecutive day period.
  4. If, upon review of information regarding the use of a drug pursuant to this section, the Department determines that significant adverse effects are likely to occur, it may restrict or limit use of the drug.
3. **Extralabel drug use.** Extralabel drug use is not authorized by this permit, unless in accordance with a specific prescription written for that use by a licensed veterinarian.
  - a. Notification. The permittee must notify the Department orally or by e-mail prior to initial extralabel use of a drug.
    1. The notification must include a description of the drug, its intended purpose, the method of application, the amount, concentration, and duration of the use, information on aquatic toxicity, and a description of how and why the use qualifies as an extralabel drug use under FDA requirements.
    2. **Within seven (7) days of the initial notification**, the permittee must submit a written report that includes all of the information outlined in Section I.3(a)(1) above. Notice must include documentation that a veterinarian has prescribed the drug for the proposed use. A copy of the veterinarian's prescription must be maintained on-site during treatment for Department review.
    3. If, upon review of information regarding the extralabel use of a drug pursuant to this section, the Department determines that significant adverse effects are likely to occur, it may deny, restrict or limit use of the drug.

## SPECIAL CONDITIONS

### I. DISEASE CONTROL (cont'd)

4. **Investigational New Animal Drug (INAD).** The discharge of drugs authorized by the FDA for use during studies conducted under the INAD program is not authorized by this permit, unless in accordance with specific prior consent given in writing by the Department.
  - a. Initial report. The permittee must provide a written report to the Department for the proposed use of an INAD *within seven (7) days* of agreeing or signing up to participate in an INAD study. The written report must identify the INAD to be used, method of use, dosage, and disease or condition the INAD is intended to treat.
  - b. Evaluation and monitoring. *At least ninety (90) days prior to initial use* of an INAD at a facility, the permittee must submit for Department review and approval a study plan for the use of the drug that:
    1. Indicates the date the facility agreed or signed up to participate in the INAD study.
    2. Demonstrates that the minimum amount of drug necessary to evaluate its safety, efficacy, and possible environmental impacts will be used.
    3. Includes an environmental monitoring and evaluation program that at a minimum describes sampling strategies, analytical procedures, evaluation techniques and a timetable for completion of the program. Currently available data or literature that adequately characterizes the environmental fate of the INAD and its metabolite(s) may be proposed for consideration in determinations of environmental monitoring and evaluation programs required by the Department pursuant to this section.
  - c. Notification. The permittee must notify the Department orally or by electronic mail *no more than forty-eight (48) hours after* beginning the first use of the INAD under the approved plan.

### J. SPILLS

In the event of a spill of drugs, chemicals, feed, petroleum and/or hazardous waste products that results in a discharge to waters of the State, the permittee must provide an oral report of the spill to the Department within 24 hours of its occurrence and a written report on a form provided by the Department, within five (5) days to the Department. The report must include the identity and quantity of the material spilled.



## **SPECIAL CONDITIONS**

### **K. PROTECTION OF ATLANTIC SALMON**

The permittee is required to employ a fully functional Containment Management System (CMS) designed, constructed, operated, and audited so as to prevent the accidental or consequential escape of fish from the facility.

Each CMS plan must include:

1. a site plan or schematic;
2. site plan description;
3. procedures for inventory control, escape response; and unusual event management;
4. provisions for employee training, auditing methods, and record keeping requirements; and
5. the CMS must identify critical control points where escapes could potentially occur, specific control mechanisms for each of these points, and monitoring procedures to verify the effectiveness of controls.

The CMS site specific plan must also describe the use of effective containment barriers appropriate to the life stage of the fish. The facility must have in place both a three-barrier system for fish up to 5 grams in size and a two-barrier system for fish 5 grams in size or larger.

The three-barrier system must include one barrier at the incubation/rearing unit, one barrier at the effluent from the hatch house/fry rearing area, and a third barrier placed in line with the entire effluent from the facility. Each barrier must be appropriate to the size of fish being contained. The two-barrier system must include one barrier at the individual rearing unit drain and one barrier in line with the total effluent from the facility. Each barrier must be appropriate to the size of fish being contained. Barriers installed in the system may be of the screen type or some other similarly effective device used to contain fish of a specific size in a designated area. Barriers installed in the system for compliance with these requirements must be monitored daily.

Facility personnel responsible for routine operation must be properly trained and qualified to implement the CMS. Prior to any containment system assessment associated with this permit, the permittee must provide to the Department documentation of the employees' or contractors' demonstrated capabilities to conduct such work [*ICIS code 21599*].

## **SPECIAL CONDITIONS**

### **K. PROTECTION OF ATLANTIC SALMON (cont'd)**

**On or before six months following the effective date of this permit [ICIS code 53799], the permittee must submit the CMS plan to the Department, the National Marine Fisheries Service (NMFS) within the National Oceanic Atmospheric Administration (NOAA), United States Fish & Wildlife Service (USFWS), and the MDMR for review and approval and must maintain a current copy of the plan at the facility. Final approval of the plan will be determined by the Department. **The permittee may not bring eggs or any size fish into the facility until the final CMS plan is approved by the Department.****

The CMS must be audited at least once per year and within 30 days of a reportable escape by a third party qualified to conduct CMS audits and approved by the Department [ICIS code 63899]. A written report of these audits must be provided to the facility and the Department for review and approval within 30 days of the audit being conducted [ICIS code 43699]. Any time that a CMS audit identifies deficiencies, the written report must contain a corrective action plan including a timetable for implementation and provisions for re-auditing, unless waived by the Department, to verify completion of all corrective actions.

Additional third party audits to verify correction of deficiencies must be conducted in accordance with the corrective action plan or upon request of the Department. The facility must notify the Department upon completion of corrective actions.

The permittee must maintain for a period of at least five (5) years complete records, logs, reports of internal and third party audits and documents related to the CMS.

**Compromised containment/Escape reporting.** The permittee must notify by electronic mail (e-mail) the persons listed under the Escape Reporting Contact List (provided in this subsection) of any known system failures that compromise fish containment or suspected escape of any fish within 24 hours of becoming aware of the known or suspected loss.

The permittee must include in its e-mail notification the following information:

- 1) site location (town and waterbody);
- 2) date of event (or window of possible dates if exact date is unknown);
- 3) time of event (if known or specify unknown);
- 4) species (including strain);

## **SPECIAL CONDITIONS**

### **K. PROTECTION OF ATLANTIC SALMON (cont'd)**

- 5) estimated average weight;
- 6) age of escaped fish;
- 7) number of escaped fish (or if exact number is not possible, an estimate);
- 8) medication profile;
- 9) details of the escape;
- 10) corrective action(s) taken or planned;
- 11) and a contact person (including phone number) for the facility which is subject of the known or suspected escape.

#### Escape Reporting Contact List:

The agency contacts on this list may be revised by the state and/or federal agencies by provision of written notification to the permittee and the other agencies. Upon notice of any such change the permittee must notify all persons on the revised list in the same manner as provided in this protocol.

#### *Army Corps of Engineers*

Maine Project Office, Peter Tischbein, [Peter.Tischbein@usace.army.mil](mailto:Peter.Tischbein@usace.army.mil)

#### *Maine Department of Environmental Protection*

Regional Compliance Inspector, Clarissa Trasko, [Clarissa.Trasko@maine.gov](mailto:Clarissa.Trasko@maine.gov)

#### *Maine Department Marine Resources*

Secretary to the Commissioner; Amy Sinclair; [Amy.Sinclair@maine.gov](mailto:Amy.Sinclair@maine.gov)

Marine Scientist, Division of Aquaculture, Marcy Nelson, [Marcy.Nelson@maine.gov](mailto:Marcy.Nelson@maine.gov)

Director, Division of Sea-Run Fisheries, Sean Ledwin, [Sean.M.Ledwin@maine.gov](mailto:Sean.M.Ledwin@maine.gov)

#### *Maine Department of Inland Fisheries and Wildlife*

Commissioner, Judy A. Camuso, [Judy.Camuso@maine.gov](mailto:Judy.Camuso@maine.gov), or current Commissioner

#### *National Marine Fisheries Service*

Maine Field Station; David Bean, [David.Bean@noaa.gov](mailto:David.Bean@noaa.gov)

#### *United States Fish & Wildlife Service*

Maine Field Office; Wende Mahaney; [Wende\\_Mahaney@fws.gov](mailto:Wende_Mahaney@fws.gov)

## **SPECIAL CONDITIONS**

### **L. FISH FEED**

**At least 90 days prior to stocking the site with fish feed**, the permittee must submit a detailed list of ingredients in the feed. If the list contains ingredients of concern, the Department reserves the right to reopen the permit pursuant to Special Condition O, *Reopening of Permit for Modifications*, to establish additional limitations and/or monitoring requirements for the ingredients of concern.

### **M. 06-096 CMR 530(2)(D)(4) STATEMENT FOR REDUCED/WAIVED TESTING**

**By December 31 of each calendar year**, the permittee must provide the Department with a certification describing any of the following that have occurred since the effective date of this permit [*ICIS Code 96299*]. See **Attachment G** of the Fact Sheet of this permit for an acceptable certification form to satisfy this Special Condition.

- a. Changes in the number or types of waste streams contributing directly or indirectly to the wastewater treatment works that may increase the toxicity of the discharge;
- b. Changes in the operation of the treatment works that may increase the toxicity of the discharge; and
- c. Changes in the processes contributing wastewater to the treatment works that may increase the toxicity of the discharge.

The Department reserves the right to establish surveillance level chemical specific or priority pollutant testing or other toxicity testing if new information becomes available that indicates the discharge may cause or have a reasonable potential to cause exceedances of ambient water quality criteria/thresholds.

### **N. COMMENCEMENT OF OPERATIONS**

**At least 90 days prior to commencing production/operations**, the permittee must meet with the Department's permitting and compliance inspection staff to review applicability of the permit limitations, monitoring requirements and reporting requirements. Should the Department determine the proposed production/operations are significantly different than what has been presented in the October 19, 2018 application materials or supplemental application materials on record, the Department may require the permittee to submit a new application or an application for an amendment to the Department.

## **SPECIAL CONDITIONS**

### **O. REOPENING OF PERMIT FOR MODIFICATION**

In accordance with 38 M.R.S. § 414-A(5) and upon evaluation of the test results from tests required in the Special Conditions of this permit, new site specific information, or any other pertinent test results or information obtained during the term of this permit, the Department may, at any time and with notice to the permittee, modify this permit to: (1) include effluent limits necessary to control specific pollutants or whole effluent toxicity where there is a reasonable potential that the effluent may cause water quality criteria to be exceeded; (2) require additional monitoring if results on file are inconclusive; or (3) change monitoring requirements or limitations based on new information.

Without limiting the foregoing paragraph, this permit may be reopened to establish revised effluent limitations, require additional monitoring of the effluent, ambient receiving water, or change monitoring requirements if the permittee fails to substantially complete construction of Phase II of the facility within 30 months of the completion of the three grow out tanks for Phase I.

### **P. SEVERABILITY**

In the event that any provision or part thereof, of this permit is declared to be unlawful by a reviewing court, the remainder of the permit must remain in full force and effect, and must be construed and enforced in all aspects as if such unlawful provision, or part thereof, had been omitted, unless otherwise ordered by the court.





# DEP INFORMATION SHEET

## Appealing a Department Licensing Decision

**Dated: November 2018**

**Contact: (207) 287-2452**

### **SUMMARY**

There are two methods available to an aggrieved person seeking to appeal a licensing decision made by the Department of Environmental Protection's (DEP) Commissioner: (1) an administrative process before the Board of Environmental Protection (Board); or (2) a judicial process before Maine's Superior Court. An aggrieved person seeking review of a licensing decision over which the Board had original jurisdiction may seek judicial review in Maine's Superior Court.

A judicial appeal of final action by the Commissioner or the Board regarding an application for an expedited wind energy development (35-A M.R.S. § 3451(4)) or a general permit for an offshore wind energy demonstration project (38 M.R.S. § 480-HH(1)) or a general permit for a tidal energy demonstration project (38 M.R.S. § 636-A) must be taken to the Supreme Judicial Court sitting as the Law Court.

This information sheet, in conjunction with a review of the statutory and regulatory provisions referred to herein, can help a person to understand his or her rights and obligations in filing an administrative or judicial appeal.

### **I. ADMINISTRATIVE APPEALS TO THE BOARD**

#### **LEGAL REFERENCES**

The laws concerning the DEP's *Organization and Powers*, 38 M.R.S. §§ 341-D(4) & 346; the *Maine Administrative Procedure Act*, 5 M.R.S. § 11001; and the DEP's *Rules Concerning the Processing of Applications and Other Administrative Matters* ("Chapter 2"), 06-096 C.M.R. ch. 2.

#### **DEADLINE TO SUBMIT AN APPEAL TO THE BOARD**

The Board must receive a written appeal within 30 days of the date on which the Commissioner's decision was filed with the Board. Appeals filed more than 30 calendar days after the date on which the Commissioner's decision was filed with the Board will be dismissed unless notice of the Commissioner's license decision was required to be given to the person filing an appeal (appellant) and the notice was not given as required.

#### **HOW TO SUBMIT AN APPEAL TO THE BOARD**

Signed original appeal documents must be sent to: Chair, Board of Environmental Protection, 17 State House Station, Augusta, ME 04333-0017. An appeal may be submitted by fax or e-mail if it contains a scanned original signature. It is recommended that a faxed or e-mailed appeal be followed by the submittal of mailed original paper documents. The complete appeal, including any attachments, must be received at DEP's offices in Augusta on or before 5:00 PM on the due date; materials received after 5:00 pm are not considered received until the following day. The risk of material not being received in a timely manner is on the sender, regardless of the method used. The appellant must also send a copy of the appeal documents to the Commissioner of the DEP; the applicant (if the appellant is not the applicant in the license proceeding at issue); and if a hearing was held on the application, any intervenor in that hearing process. All of the information listed in the next section of this information sheet must be submitted at the time the appeal is filed.

### **INFORMATION APPEAL PAPERWORK MUST CONTAIN**

Appeal materials must contain the following information at the time the appeal is submitted:

1. *Aggrieved Status.* The appeal must explain how the appellant has standing to maintain an appeal. This requires an explanation of how the appellant may suffer a particularized injury as a result of the Commissioner's decision.
2. *The findings, conclusions, or conditions objected to or believed to be in error.* The appeal must identify the specific findings of fact, conclusions regarding compliance with the law, license conditions, or other aspects of the written license decision or of the license review process that the appellant objects to or believes to be in error.
3. *The basis of the objections or challenge.* For the objections identified in Item #2, the appeal must state why the appellant believes that the license decision is incorrect and should be modified or reversed. If possible, the appeal should cite specific evidence in the record or specific licensing requirements that the appellant believes were not properly considered or fully addressed.
4. *The remedy sought.* This can range from reversal of the Commissioner's decision on the license or permit to changes in specific permit conditions.
5. *All the matters to be contested.* The Board will limit its consideration to those matters specifically raised in the written notice of appeal.
6. *Request for hearing.* If the appellant wishes the Board to hold a public hearing on the appeal, a request for public hearing must be filed as part of the notice of appeal, and must include an offer of proof in accordance with Chapter 2. The Board will hear the arguments in favor of and in opposition to a hearing on the appeal and the presentations on the merits of an appeal at a regularly scheduled meeting. If the Board decides to hold a public hearing on an appeal, that hearing will then be scheduled for a later date.
7. *New or additional evidence to be offered.* If an appellant wants to provide evidence not previously provided to DEP staff during the DEP's review of the application, the request and the proposed evidence must be submitted with the appeal. The Board may allow new or additional evidence, referred to as supplemental evidence, to be considered in an appeal only under very limited circumstances. The proposed evidence must be relevant and material, and (a) the person seeking to add information to the record must show due diligence in bringing the evidence to the DEP's attention at the earliest possible time in the licensing process; or (b) the evidence itself must be newly discovered and therefore unable to have been presented earlier in the process. Specific requirements for supplemental evidence are found in Chapter 2 § 24.

### **OTHER CONSIDERATIONS IN APPEALING A DECISION TO THE BOARD**

1. *Be familiar with all relevant material in the DEP record.* A license application file is public information, subject to any applicable statutory exceptions, and is made easily accessible by the DEP. Upon request, the DEP will make application materials available during normal working hours, provide space to review the file, and provide an opportunity for photocopying materials. There is a charge for copies or copying services.
2. *Be familiar with the regulations and laws under which the application was processed, and the procedural rules governing your appeal.* DEP staff will provide this information on request and answer general questions regarding the appeal process.
3. *The filing of an appeal does not operate as a stay to any decision.* If a license has been granted and it has been appealed, the license normally remains in effect pending the processing of the appeal. Unless a stay of the decision is requested and granted, a license holder may proceed with a project pending the outcome of an appeal, but the license holder runs the risk of the decision being reversed or modified as a result of the appeal.



## **WHAT TO EXPECT ONCE YOU FILE A TIMELY APPEAL WITH THE BOARD**

The Board will formally acknowledge receipt of an appeal, and will provide the name of the DEP project manager assigned to the specific appeal. The notice of appeal, any materials accepted by the Board Chair as supplementary evidence, any materials submitted in response to the appeal, and relevant excerpts from the DEP's application review file will be sent to Board members with a recommended decision from DEP staff. The appellant, the license holder if different from the appellant, and any interested persons are notified in advance of the date set for Board consideration of an appeal or request for public hearing. The appellant and the license holder will have an opportunity to address the Board at the Board meeting. With or without holding a public hearing, the Board may affirm, amend, or reverse a Commissioner decision or remand the matter to the Commissioner for further proceedings. The Board will notify the appellant, the license holder, and interested persons of its decision.

## **II. JUDICIAL APPEALS**

Maine law generally allows aggrieved persons to appeal final Commissioner or Board licensing decisions to Maine's Superior Court (see 38 M.R.S. § 346(1); 06-096 C.M.R. ch. 2; 5 M.R.S. § 11001; and M.R. Civ. P. 80C). A party's appeal must be filed with the Superior Court within 30 days of receipt of notice of the Board's or the Commissioner's decision. For any other person, an appeal must be filed within 40 days of the date the decision was rendered. An appeal to court of a license decision regarding an expedited wind energy development, a general permit for an offshore wind energy demonstration project, or a general permit for a tidal energy demonstration project may only be taken directly to the Maine Supreme Judicial Court. See 38 M.R.S. § 346(4).

Maine's Administrative Procedure Act, DEP statutes governing a particular matter, and the Maine Rules of Civil Procedure must be consulted for the substantive and procedural details applicable to judicial appeals.

## **ADDITIONAL INFORMATION**

If you have questions or need additional information on the appeal process, for administrative appeals contact the Board's Executive Analyst at (207) 287-2452, or for judicial appeals contact the court clerk's office in which your appeal will be filed.

---

**Note: The DEP provides this INFORMATION SHEET for general guidance only; it is not intended for use as a legal reference. Maine law governs an appellant's rights.**

---

# **ATTACHMENT A**

## Protocol for Nitrogen Sample Collection and Analysis for Waste Water Effluent

Approved Analytical Methods (from Table 1 B of Part 136 per the 2012 Method Update Rule): (laboratory must be certified for any method performed)

### Total Kjeldahl Nitrogen (TKN):

Manual digestion and distillation or gas diffusion followed by any of the following	SM4500-Norg B-97 or C-97 and SM4500-NH3 B-97.	ASTM D3590-02 (06) (A)	I-4515-9145
Titration	SM4500-NH3 C-97	ASTM D3590-89, 02 (A)	973.48.3
Nesslerization		ASTM D1426-08 (A)	
Electrode	SM4500-NH3 D-97 or E-97	ASTM D1426-08 (B)	
Semi-automated phenate	EPA 350.1 Rev. 2.0 (1993)	SM4500-NH3 G-97 or H-97	
Manual phenate, salicylate, or other substituted phenols in Berthelot reaction based methods	SM4500-NH3 F-1997		
<b><i>Automated methods for TKN that do not require manual digestion</i></b>			
Automated phenate, salicylate, or other substituted phenols in Berthelot reaction based methods colorimetric (auto digestion and distillation)	EPA 351.1 (1978)		I-4551-788
Semi-automated block digester colorimetric (distillation not required)	EPA 351.2, Rev. 2.0 (1993)	SM4500-Norg D-97	ASTM D3590-02 (06) (B) I-4515-9145

**Nitrate + Nitrite (NO<sub>3</sub> + NO<sub>2</sub>):**

Cadmium reduction, Manual		SM4500-NO3 E-00	ASTM D3867-04 (B)	
Cadmium reduction, Automated, or	EPA 353.2, Rev. 2.0 (1993)	SM4500-NO3 F-00	ASTM D3867-04(A)	I-4545-852
Automated hydrazine		SM4500-NO3 H-00		
Ion chromatography	EPA 300.0, Rev. 2.1 (1993) and EPA 300.1, rev. 1.0 (1997)	SM4110 B-00 or C-00	ASTM D4327-03	993.303
CIE/UV		SM4140 B-97	ASTM D6508-00 (05)	ASTM D6508, Rev. 2

**Sample Collection:** The Maine DEP is requesting that nitrogen analysis be conducted on composite effluent samples, unless a facility's Permit specifically designates grab sampling for this parameter. Facilities can use individual collection bottles or a single jug made out of glass or polyethylene. Bottles and/or jugs should be cleaned prior to each use with dilute H<sub>2</sub>SO<sub>4</sub>. This cleaning should be followed by several rinses with distilled water. Commercially purchased, pre-cleaned sample containers are an acceptable alternative. The sampler hoses should be cleaned; as needed.

**Sample Preservation:** During compositing the sample must be at 0-6 degrees C (without freezing). If the sample is being sent to a commercial laboratory or analysis cannot be performed the day of collection then the sample must be preserved using H<sub>2</sub>SO<sub>4</sub> to obtain a sample pH of <2 su and refrigerated at 0-6 degrees C (without freezing). The holding time for a preserved sample is 28 days.

**Laboratory QA/QC:** Laboratories must follow the appropriate QA/QC procedures that are described in each of the approved methods.

**Sampling QA/QC:** If a composite sample is being collected using an automated sampler, then once per month run a blank on the composite sampler. Automatically, draw distilled water into the sample jug using the sample collection line. Let this water set in the jug for 24 hours and then analyze for total nitrogen. Preserve this sample as described above.

# **ATTACHMENT B**

## **Protocol for Total Phosphorus Sample Collection and Analysis for Waste Water and Receiving Water Monitoring Required by Permits**

Approved Analytical Methods: EPA 200.7 (Rev. 44), 365.1 (Rev. 2.0), (Lachat), 365.3, 365.4; SM 3120 B, 4500-P B.5, 4500-P E, 4500-P F, 4500-P G, 4500-P H; ASTM D515-88(A), D515-88(B); USGS I-4471-97, I-4600-85, I-4610-91; OMAAOAC 973.55, 973.56

**Sample Collection:** The Maine DEP is requesting that total phosphorus analysis be conducted on composite effluent samples, unless a facility's Permit specifically designates grab sampling for this parameter. Facilities can use individual collection bottles or a single jug made out of glass or polyethylene. Bottles and/or jugs should be cleaned prior to each use with dilute HCL. This cleaning should be followed by several rinses with distilled water. Commercially purchased, pre-cleaned sample containers are an acceptable alternative. The sampler hoses should be cleaned, as needed.

**Sample Preservation:** During compositing the sample must be at 0-6 degrees C (without freezing). If the sample is being sent to a commercial laboratory or analysis cannot be performed the day of collection then the sample must be preserved using H<sub>2</sub>SO<sub>4</sub> to obtain a sample pH of <2 su and refrigerated at 0-6 degrees C (without freezing). The holding time for a preserved sample is 28 days.

**Note:** Ideally, Total P samples are preserved as described above. However, if a facility is using a commercial laboratory then that laboratory may choose to add acid to the sample once it arrives at the laboratory. The Maine DEP will accept results that use either of these preservation methods.

**Laboratory QA/QC:** Laboratories must follow the appropriate QA/QC procedures that are described in each of the approved methods.

**Sampling QA/QC:** If a composite sample is being collected using an automated sampler, then once per month run a blank on the composite sampler. Automatically, draw distilled water into the sample jug using the sample collection line. Let this water set in the jug for 24 hours and then analyze for total phosphorus. Preserve this sample as described above.

MAINE POLLUTANT DISCHARGE ELIMINATION SYSTEM PERMIT

STANDARD CONDITIONS APPLICABLE TO ALL PERMITS

---

CONTENTS

SECTION	TOPIC	PAGE
A	GENERAL PROVISIONS	
1	General compliance	2
2	Other materials	2
3	Duty to Comply	2
4	Duty to provide information	2
5	Permit actions	2
6	Reopener clause	2
7	Oil and hazardous substances	2
8	Property rights	3
9	Confidentiality	3
10	Duty to reapply	3
11	Other laws	3
12	Inspection and entry	3
B	OPERATION AND MAINTENANCE OF FACILITIES	
1	General facility requirements	3
2	Proper operation and maintenance	4
3	Need to halt reduce not a defense	4
4	Duty to mitigate	4
5	Bypasses	4
6	Upsets	5
C	MONITORING AND RECORDS	
1	General requirements	6
2	Representative sampling	6
3	Monitoring and records	6
D	REPORTING REQUIREMENTS	
1	Reporting requirements	7
2	Signatory requirement	8
3	Availability of reports	8
4	Existing manufacturing, commercial, mining, and silvicultural dischargers	8
5	Publicly owned treatment works	9
E	OTHER PROVISIONS	
1	Emergency action - power failure	9
2	Spill prevention	10
3	Removed substances	10
4	Connection to municipal sewer	10
F	DEFINITIONS	10

MAINE POLLUTANT DISCHARGE ELIMINATION SYSTEM PERMIT

STANDARD CONDITIONS APPLICABLE TO ALL PERMITS

---

**A. GENERAL PROVISIONS**

**1. General compliance.** All discharges shall be consistent with the terms and conditions of this permit; any changes in production capacity or process modifications which result in changes in the quantity or the characteristics of the discharge must be authorized by an additional license or by modifications of this permit; it shall be a violation of the terms and conditions of this permit to discharge any pollutant not identified and authorized herein or to discharge in excess of the rates or quantities authorized herein or to violate any other conditions of this permit.

**2. Other materials.** Other materials ordinarily produced or used in the operation of this facility, which have been specifically identified in the application, may be discharged at the maximum frequency and maximum level identified in the application, provided:

- (a) They are not
  - (i) Designated as toxic or hazardous under the provisions of Sections 307 and 311, respectively, of the Federal Water Pollution Control Act; Title 38, Section 420, Maine Revised Statutes; or other applicable State Law; or
  - (ii) Known to be hazardous or toxic by the licensee.
- (b) The discharge of such materials will not violate applicable water quality standards.

**3. Duty to comply.** The permittee must comply with all conditions of this permit. Any permit noncompliance constitutes a violation of State law and the Clean Water Act and is grounds for enforcement action; for permit termination, revocation and reissuance, or modification; or denial of a permit renewal application.

- (a) The permittee shall comply with effluent standards or prohibitions established under section 307(a) of the Clean Water Act, and 38 MRSA, §420 or Chapter 530.5 for toxic pollutants within the time provided in the regulations that establish these standards or prohibitions, even if the permit has not yet been modified to incorporate the requirement.
- (b) Any person who violates any provision of the laws administered by the Department, including without limitation, a violation of the terms of any order, rule license, permit, approval or decision of the Board or Commissioner is subject to the penalties set forth in 38 MRSA, §349.

**4. Duty to provide information.** The permittee shall furnish to the Department, within a reasonable time, any information which the Department may request to determine whether cause exists for modifying, revoking and reissuing, or terminating this permit or to determine compliance with this permit. The permittee shall also furnish to the Department upon request, copies of records required to be kept by this permit.

**5. Permit actions.** This permit may be modified, revoked and reissued, or terminated for cause. The filing of a request by the permittee for a permit modification, revocation and reissuance, or termination, or a notification of planned changes or anticipated noncompliance does not stay any permit condition.

**6. Reopener clause.** The Department reserves the right to make appropriate revisions to this permit in order to establish any appropriate effluent limitations, schedule of compliance or other provisions which may be authorized under 38 MRSA, §414-A(5).



MAINE POLLUTANT DISCHARGE ELIMINATION SYSTEM PERMIT

STANDARD CONDITIONS APPLICABLE TO ALL PERMITS

---

**7. Oil and hazardous substances.** Nothing in this permit shall be construed to preclude the institution of any legal action or relieve the permittee from any responsibilities, liabilities or penalties to which the permittee is or may be subject under section 311 of the Federal Clean Water Act; section 106 of the Federal Comprehensive Environmental Response, Compensation and Liability Act of 1980; or 38 MRSA §§ 1301, et. seq.

**8. Property rights.** This permit does not convey any property rights of any sort, or any exclusive privilege.

**9. Confidentiality of records.** 38 MRSA §414(6) reads as follows. "Any records, reports or information obtained under this subchapter is available to the public, except that upon a showing satisfactory to the department by any person that any records, reports or information, or particular part or any record, report or information, other than the names and addresses of applicants, license applications, licenses, and effluent data, to which the department has access under this subchapter would, if made public, divulge methods or processes that are entitled to protection as trade secrets, these records, reports or information must be confidential and not available for public inspection or examination. Any records, reports or information may be disclosed to employees or authorized representatives of the State or the United States concerned with carrying out this subchapter or any applicable federal law, and to any party to a hearing held under this section on terms the commissioner may prescribe in order to protect these confidential records, reports and information, as long as this disclosure is material and relevant to any issue under consideration by the department."

**10. Duty to reapply.** If the permittee wishes to continue an activity regulated by this permit after the expiration date of this permit, the permittee must apply for and obtain a new permit.

**11. Other laws.** The issuance of this permit does not authorize any injury to persons or property or invasion of other property rights, nor does it relieve the permittee of its obligation to comply with other applicable Federal, State or local laws and regulations.

**12. Inspection and entry.** The permittee shall allow the Department, or an authorized representative (including an authorized contractor acting as a representative of the EPA Administrator), upon presentation of credentials and other documents as may be required by law, to:

- (a) Enter upon the permittee's premises where a regulated facility or activity is located or conducted, or where records must be kept under the conditions of this permit;
- (b) Have access to and copy, at reasonable times, any records that must be kept under the conditions of this permit;
- (c) Inspect at reasonable times any facilities, equipment (including monitoring and control equipment), practices, or operations regulated or required under this permit; and
- (d) Sample or monitor at reasonable times, for the purposes of assuring permit compliance or as otherwise authorized by the Clean Water Act, any substances or parameters at any location.

**B. OPERATION AND MAINTENANCE OF FACILITIES**

**1. General facility requirements.**

- (a) The permittee shall collect all waste flows designated by the Department as requiring treatment and discharge them into an approved waste treatment facility in such a manner as to

MAINE POLLUTANT DISCHARGE ELIMINATION SYSTEM PERMIT

STANDARD CONDITIONS APPLICABLE TO ALL PERMITS

---

- maximize removal of pollutants unless authorization to the contrary is obtained from the Department.
- (b) The permittee shall at all times maintain in good working order and operate at maximum efficiency all waste water collection, treatment and/or control facilities.
  - (c) All necessary waste treatment facilities will be installed and operational prior to the discharge of any wastewaters.
  - (d) Final plans and specifications must be submitted to the Department for review prior to the construction or modification of any treatment facilities.
  - (e) The permittee shall install flow measuring facilities of a design approved by the Department.
  - (f) The permittee must provide an outfall of a design approved by the Department which is placed in the receiving waters in such a manner that the maximum mixing and dispersion of the wastewaters will be achieved as rapidly as possible.

**2. Proper operation and maintenance.** The permittee shall at all times properly operate and maintain all facilities and systems of treatment and control (and related appurtenances) which are installed or used by the permittee to achieve compliance with the conditions of this permit. Proper operation and maintenance also includes adequate laboratory controls and appropriate quality assurance procedures. This provision requires the operation of back-up or auxiliary facilities or similar systems which are installed by a permittee only when the operation is necessary to achieve compliance with the conditions of the permit.

**3. Need to halt or reduce activity not a defense.** It shall not be a defense for a permittee in an enforcement action that it would have been necessary to halt or reduce the permitted activity in order to maintain compliance with the conditions of this permit.

**4. Duty to mitigate.** The permittee shall take all reasonable steps to minimize or prevent any discharge or sludge use or disposal in violation of this permit which has a reasonable likelihood of adversely affecting human health or the environment.

**5. Bypasses.**

- (a) Definitions.
  - (i) Bypass means the intentional diversion of waste streams from any portion of a treatment facility.
  - (ii) Severe property damage means substantial physical damage to property, damage to the treatment facilities which causes them to become inoperable, or substantial and permanent loss of natural resources which can reasonably be expected to occur in the absence of a bypass. Severe property damage does not mean economic loss caused by delays in production.
- (b) Bypass not exceeding limitations. The permittee may allow any bypass to occur which does not cause effluent limitations to be exceeded, but only if it also is for essential maintenance to assure efficient operation. These bypasses are not subject to the provisions of paragraphs (c) and (d) of this section.
- (c) Notice.
  - (i) Anticipated bypass. If the permittee knows in advance of the need for a bypass, it shall submit prior notice, if possible at least ten days before the date of the bypass.

MAINE POLLUTANT DISCHARGE ELIMINATION SYSTEM PERMIT

STANDARD CONDITIONS APPLICABLE TO ALL PERMITS

---

- (ii) Unanticipated bypass. The permittee shall submit notice of an unanticipated bypass as required in paragraph D(1)(f), below. (24-hour notice).
- (d) Prohibition of bypass.
  - (i) Bypass is prohibited, and the Department may take enforcement action against a permittee for bypass, unless:
    - (A) Bypass was unavoidable to prevent loss of life, personal injury, or severe property damage;
    - (B) There were no feasible alternatives to the bypass, such as the use of auxiliary treatment facilities, retention of untreated wastes, or maintenance during normal periods of equipment downtime. This condition is not satisfied if adequate back-up equipment should have been installed in the exercise of reasonable engineering judgment to prevent a bypass which occurred during normal periods of equipment downtime or preventive maintenance; and
    - (C) The permittee submitted notices as required under paragraph (c) of this section.
  - (ii) The Department may approve an anticipated bypass, after considering its adverse effects, if the Department determines that it will meet the three conditions listed above in paragraph (d)(i) of this section.

**6. Upsets.**

- (a) Definition. Upset means an exceptional incident in which there is unintentional and temporary noncompliance with technology based permit effluent limitations because of factors beyond the reasonable control of the permittee. An upset does not include noncompliance to the extent caused by operational error, improperly designed treatment facilities, inadequate treatment facilities, lack of preventive maintenance, or careless or improper operation.
- (b) Effect of an upset. An upset constitutes an affirmative defense to an action brought for noncompliance with such technology based permit effluent limitations if the requirements of paragraph (c) of this section are met. No determination made during administrative review of claims that noncompliance was caused by upset, and before an action for noncompliance, is final administrative action subject to judicial review.
- (c) Conditions necessary for a demonstration of upset. A permittee who wishes to establish the affirmative defense of upset shall demonstrate, through properly signed, contemporaneous operating logs, or other relevant evidence that:
  - (i) An upset occurred and that the permittee can identify the cause(s) of the upset;
  - (ii) The permitted facility was at the time being properly operated; and
  - (iii) The permittee submitted notice of the upset as required in paragraph D(1)(f) , below. (24 hour notice).
  - (iv) The permittee complied with any remedial measures required under paragraph B(4).
- (d) Burden of proof. In any enforcement proceeding the permittee seeking to establish the occurrence of an upset has the burden of proof.

MAINE POLLUTANT DISCHARGE ELIMINATION SYSTEM PERMIT

STANDARD CONDITIONS APPLICABLE TO ALL PERMITS

---

**C. MONITORING AND RECORDS**

**1. General Requirements.** This permit shall be subject to such monitoring requirements as may be reasonably required by the Department including the installation, use and maintenance of monitoring equipment or methods (including, where appropriate, biological monitoring methods). The permittee shall provide the Department with periodic reports on the proper Department reporting form of monitoring results obtained pursuant to the monitoring requirements contained herein.

**2. Representative sampling.** Samples and measurements taken as required herein shall be representative of the volume and nature of the monitored discharge. If effluent limitations are based wholly or partially on quantities of a product processed, the permittee shall ensure samples are representative of times when production is taking place. Where discharge monitoring is required when production is less than 50%, the resulting data shall be reported as a daily measurement but not included in computation of averages, unless specifically authorized by the Department.

**3. Monitoring and records.**

- (a) Samples and measurements taken for the purpose of monitoring shall be representative of the monitored activity.
- (b) Except for records of monitoring information required by this permit related to the permittee's sewage sludge use and disposal activities, which shall be retained for a period of at least five years, the permittee shall retain records of all monitoring information, including all calibration and maintenance records and all original strip chart recordings for continuous monitoring instrumentation, copies of all reports required by this permit, and records of all data used to complete the application for this permit, for a period of at least 3 years from the date of the sample, measurement, report or application. This period may be extended by request of the Department at any time.
- (c) Records of monitoring information shall include:
  - (i) The date, exact place, and time of sampling or measurements;
  - (ii) The individual(s) who performed the sampling or measurements;
  - (iii) The date(s) analyses were performed;
  - (iv) The individual(s) who performed the analyses;
  - (v) The analytical techniques or methods used; and
  - (vi) The results of such analyses.
- (d) Monitoring results must be conducted according to test procedures approved under 40 CFR part 136, unless other test procedures have been specified in the permit.
- (e) State law provides that any person who tampers with or renders inaccurate any monitoring devices or method required by any provision of law, or any order, rule license, permit approval or decision is subject to the penalties set forth in 38 MRSA, §349.

MAINE POLLUTANT DISCHARGE ELIMINATION SYSTEM PERMIT

STANDARD CONDITIONS APPLICABLE TO ALL PERMITS

---

**D. REPORTING REQUIREMENTS**

**1. Reporting requirements.**

- (a) Planned changes. The permittee shall give notice to the Department as soon as possible of any planned physical alterations or additions to the permitted facility. Notice is required only when:
  - (i) The alteration or addition to a permitted facility may meet one of the criteria for determining whether a facility is a new source in 40 CFR 122.29(b); or
  - (ii) The alteration or addition could significantly change the nature or increase the quantity of pollutants discharged. This notification applies to pollutants which are subject neither to effluent limitations in the permit, nor to notification requirements under Section D(4).
  - (iii) The alteration or addition results in a significant change in the permittee's sludge use or disposal practices, and such alteration, addition, or change may justify the application of permit conditions that are different from or absent in the existing permit, including notification of additional use or disposal sites not reported during the permit application process or not reported pursuant to an approved land application plan;
- (b) Anticipated noncompliance. The permittee shall give advance notice to the Department of any planned changes in the permitted facility or activity which may result in noncompliance with permit requirements.
- (c) Transfers. This permit is not transferable to any person except upon application to and approval of the Department pursuant to 38 MRSA, § 344 and Chapters 2 and 522.
- (d) Monitoring reports. Monitoring results shall be reported at the intervals specified elsewhere in this permit.
  - (i) Monitoring results must be reported on a Discharge Monitoring Report (DMR) or forms provided or specified by the Department for reporting results of monitoring of sludge use or disposal practices.
  - (ii) If the permittee monitors any pollutant more frequently than required by the permit using test procedures approved under 40 CFR part 136 or as specified in the permit, the results of this monitoring shall be included in the calculation and reporting of the data submitted in the DMR or sludge reporting form specified by the Department.
  - (iii) Calculations for all limitations which require averaging of measurements shall utilize an arithmetic mean unless otherwise specified by the Department in the permit.
- (e) Compliance schedules. Reports of compliance or noncompliance with, or any progress reports on, interim and final requirements contained in any compliance schedule of this permit shall be submitted no later than 14 days following each schedule date.
- (f) Twenty-four hour reporting.
  - (i) The permittee shall report any noncompliance which may endanger health or the environment. Any information shall be provided orally within 24 hours from the time the permittee becomes aware of the circumstances. A written submission shall also be provided within 5 days of the time the permittee becomes aware of the circumstances. The written submission shall contain a description of the noncompliance and its cause; the period of noncompliance, including exact dates and times, and if the noncompliance

MAINE POLLUTANT DISCHARGE ELIMINATION SYSTEM PERMIT

STANDARD CONDITIONS APPLICABLE TO ALL PERMITS

---

has not been corrected, the anticipated time it is expected to continue; and steps taken or planned to reduce, eliminate, and prevent reoccurrence of the noncompliance.

(ii) The following shall be included as information which must be reported within 24 hours under this paragraph.

(A) Any unanticipated bypass which exceeds any effluent limitation in the permit.

(B) Any upset which exceeds any effluent limitation in the permit.

(C) Violation of a maximum daily discharge limitation for any of the pollutants listed by the Department in the permit to be reported within 24 hours.

(iii) The Department may waive the written report on a case-by-case basis for reports under paragraph (f)(ii) of this section if the oral report has been received within 24 hours.

(g) Other noncompliance. The permittee shall report all instances of noncompliance not reported under paragraphs (d), (e), and (f) of this section, at the time monitoring reports are submitted. The reports shall contain the information listed in paragraph (f) of this section.

(h) Other information. Where the permittee becomes aware that it failed to submit any relevant facts in a permit application, or submitted incorrect information in a permit application or in any report to the Department, it shall promptly submit such facts or information.

**2. Signatory requirement.** All applications, reports, or information submitted to the Department shall be signed and certified as required by Chapter 521, Section 5 of the Department's rules. State law provides that any person who knowingly makes any false statement, representation or certification in any application, record, report, plan or other document filed or required to be maintained by any order, rule, permit, approval or decision of the Board or Commissioner is subject to the penalties set forth in 38 MRSA, §349.

**3. Availability of reports.** Except for data determined to be confidential under A(9), above, all reports prepared in accordance with the terms of this permit shall be available for public inspection at the offices of the Department. As required by State law, effluent data shall not be considered confidential. Knowingly making any false statement on any such report may result in the imposition of criminal sanctions as provided by law.

**4. Existing manufacturing, commercial, mining, and silvicultural dischargers.** In addition to the reporting requirements under this Section, all existing manufacturing, commercial, mining, and silvicultural dischargers must notify the Department as soon as they know or have reason to believe:

(a) That any activity has occurred or will occur which would result in the discharge, on a routine or frequent basis, of any toxic pollutant which is not limited in the permit, if that discharge will exceed the highest of the following "notification levels":

(i) One hundred micrograms per liter (100 ug/l);

(ii) Two hundred micrograms per liter (200 ug/l) for acrolein and acrylonitrile; five hundred micrograms per liter (500 ug/l) for 2,4-dinitrophenol and for 2-methyl-4,6-dinitrophenol; and one milligram per liter (1 mg/l) for antimony;

(iii) Five (5) times the maximum concentration value reported for that pollutant in the permit application in accordance with Chapter 521 Section 4(g)(7); or

(iv) The level established by the Department in accordance with Chapter 523 Section 5(f).

MAINE POLLUTANT DISCHARGE ELIMINATION SYSTEM PERMIT

STANDARD CONDITIONS APPLICABLE TO ALL PERMITS

---

- (b) That any activity has occurred or will occur which would result in any discharge, on a non-routine or infrequent basis, of a toxic pollutant which is not limited in the permit, if that discharge will exceed the highest of the following "notification levels":
  - (i) Five hundred micrograms per liter (500 ug/l);
  - (ii) One milligram per liter (1 mg/l) for antimony;
  - (iii) Ten (10) times the maximum concentration value reported for that pollutant in the permit application in accordance with Chapter 521 Section 4(g)(7); or
  - (iv) The level established by the Department in accordance with Chapter 523 Section 5(f).

**5. Publicly owned treatment works.**

- (a) All POTWs must provide adequate notice to the Department of the following:
  - (i) Any new introduction of pollutants into the POTW from an indirect discharger which would be subject to section 301 or 306 of CWA or Chapter 528 if it were directly discharging those pollutants.
  - (ii) Any substantial change in the volume or character of pollutants being introduced into that POTW by a source introducing pollutants into the POTW at the time of issuance of the permit.
  - (iii) For purposes of this paragraph, adequate notice shall include information on (A) the quality and quantity of effluent introduced into the POTW, and (B) any anticipated impact of the change on the quantity or quality of effluent to be discharged from the POTW.
- (b) When the effluent discharged by a POTW for a period of three consecutive months exceeds 80 percent of the permitted flow, the permittee shall submit to the Department a projection of loadings up to the time when the design capacity of the treatment facility will be reached, and a program for maintaining satisfactory treatment levels consistent with approved water quality management plans.

**E. OTHER REQUIREMENTS**

**1. Emergency action - power failure.** Within thirty days after the effective date of this permit, the permittee shall notify the Department of facilities and plans to be used in the event the primary source of power to its wastewater pumping and treatment facilities fails as follows.

- (a) For municipal sources. During power failure, all wastewaters which are normally treated shall receive a minimum of primary treatment and disinfection. Unless otherwise approved, alternate power supplies shall be provided for pumping stations and treatment facilities. Alternate power supplies shall be on-site generating units or an outside power source which is separate and independent from sources used for normal operation of the wastewater facilities.
- (b) For industrial and commercial sources. The permittee shall either maintain an alternative power source sufficient to operate the wastewater pumping and treatment facilities or halt, reduce or otherwise control production and or all discharges upon reduction or loss of power to the wastewater pumping or treatment facilities.

MAINE POLLUTANT DISCHARGE ELIMINATION SYSTEM PERMIT

STANDARD CONDITIONS APPLICABLE TO ALL PERMITS

---

**2. Spill prevention.** (applicable only to industrial sources) Within six months of the effective date of this permit, the permittee shall submit to the Department for review and approval, with or without conditions, a spill prevention plan. The plan shall delineate methods and measures to be taken to prevent and or contain any spills of pulp, chemicals, oils or other contaminates and shall specify means of disposal and or treatment to be used.

**3. Removed substances.** Solids, sludges trash rack cleanings, filter backwash, or other pollutants removed from or resulting from the treatment or control of waste waters shall be disposed of in a manner approved by the Department.

**4. Connection to municipal sewer.** (applicable only to industrial and commercial sources) All wastewaters designated by the Department as treatable in a municipal treatment system will be cosigned to that system when it is available. This permit will expire 90 days after the municipal treatment facility becomes available, unless this time is extended by the Department in writing.

**F. DEFINITIONS.** For the purposes of this permit, the following definitions shall apply. Other definitions applicable to this permit may be found in Chapters 520 through 529 of the Department's rules

**Average** means the arithmetic mean of values taken at the frequency required for each parameter over the specified period. For bacteria, the average shall be the geometric mean.

**Average monthly discharge limitation** means the highest allowable average of daily discharges over a calendar month, calculated as the sum of all daily discharges measured during a calendar month divided by the number of daily discharges measured during that month. Except, however, bacteriological tests may be calculated as a geometric mean.

**Average weekly discharge limitation** means the highest allowable average of daily discharges over a calendar week, calculated as the sum of all daily discharges measured during a calendar week divided by the number of daily discharges measured during that week.

**Best management practices ("BMPs")** means schedules of activities, prohibitions of practices, maintenance procedures, and other management practices to prevent or reduce the pollution of waters of the State. BMPs also include treatment requirements, operating procedures, and practices to control plant site runoff, spillage or leaks, sludge or waste disposal, or drainage from raw material storage.

**Composite sample** means a sample consisting of a minimum of eight grab samples collected at equal intervals during a 24 hour period (or a lesser period as specified in the section on monitoring and reporting) and combined proportional to the flow over that same time period.

**Continuous discharge** means a discharge which occurs without interruption throughout the operating hours of the facility, except for infrequent shutdowns for maintenance, process changes, or other similar activities.

**Daily discharge** means the discharge of a pollutant measured during a calendar day or any 24-hour period that reasonably represents the calendar day for purposes of sampling. For pollutants with limitations expressed in units of mass, the daily discharge is calculated as the total mass of the pollutant discharged over the day. For pollutants with limitations expressed in other units of measurement, the daily discharge is calculated as the average measurement of the pollutant over the day.



# MAINE POLLUTANT DISCHARGE ELIMINATION SYSTEM PERMIT

## STANDARD CONDITIONS APPLICABLE TO ALL PERMITS

---

**Discharge Monitoring Report ("DMR")** means the EPA uniform national form, including any subsequent additions, revisions, or modifications for the reporting of self-monitoring results by permittees. DMRs must be used by approved States as well as by EPA. EPA will supply DMRs to any approved State upon request. The EPA national forms may be modified to substitute the State Agency name, address, logo, and other similar information, as appropriate, in place of EPA's.

**Flow weighted composite sample** means a composite sample consisting of a mixture of aliquots collected at a constant time interval, where the volume of each aliquot is proportional to the flow rate of the discharge.

**Grab sample** means an individual sample collected in a period of less than 15 minutes.

**Interference** means a Discharge which, alone or in conjunction with a discharge or discharges from other sources, both:

- (1) Inhibits or disrupts the POTW, its treatment processes or operations, or its sludge processes, use or disposal; and
- (2) Therefore is a cause of a violation of any requirement of the POTW's NPDES permit (including an increase in the magnitude or duration of a violation) or of the prevention of sewage sludge use or disposal in compliance with the following statutory provisions and regulations or permits issued thereunder (or more stringent State or local regulations): Section 405 of the Clean Water Act, the Solid Waste Disposal Act (SWDA) (including title II, more commonly referred to as the Resource Conservation and Recovery Act (RCRA), and including State regulations contained in any State sludge management plan prepared pursuant to subtitle D of the SWDA), the Clean Air Act, the Toxic Substances Control Act, and the Marine Protection, Research and Sanctuaries Act.

**Maximum daily discharge limitation** means the highest allowable daily discharge.

**New source** means any building, structure, facility, or installation from which there is or may be a discharge of pollutants, the construction of which commenced:

- (a) After promulgation of standards of performance under section 306 of CWA which are applicable to such source, or
- (b) After proposal of standards of performance in accordance with section 306 of CWA which are applicable to such source, but only if the standards are promulgated in accordance with section 306 within 120 days of their proposal.

**Pass through** means a discharge which exits the POTW into waters of the State in quantities or concentrations which, alone or in conjunction with a discharge or discharges from other sources, is a cause of a violation of any requirement of the POTW's NPDES permit (including an increase in the magnitude or duration of a violation).

**Permit** means an authorization, license, or equivalent control document issued by EPA or an approved State to implement the requirements of 40 CFR parts 122, 123 and 124. Permit includes an NPDES general permit (Chapter 529). Permit does not include any permit which has not yet been the subject of final agency action, such as a draft permit or a proposed permit.

**Person** means an individual, firm, corporation, municipality, quasi-municipal corporation, state agency, federal agency or other legal entity.

MAINE POLLUTANT DISCHARGE ELIMINATION SYSTEM PERMIT

STANDARD CONDITIONS APPLICABLE TO ALL PERMITS

---

**Point source** means any discernible, confined and discrete conveyance, including, but not limited to, any pipe, ditch, channel, tunnel, conduit, well, discrete fissure, container, rolling stock, concentrated animal feeding operation or vessel or other floating craft, from which pollutants are or may be discharged.

**Pollutant** means dredged spoil, solid waste, junk, incinerator residue, sewage, refuse, effluent, garbage, sewage sludge, munitions, chemicals, biological or radiological materials, oil, petroleum products or byproducts, heat, wrecked or discarded equipment, rock, sand, dirt and industrial, municipal, domestic, commercial or agricultural wastes of any kind.

**Process wastewater** means any water which, during manufacturing or processing, comes into direct contact with or results from the production or use of any raw material, intermediate product, finished product, byproduct, or waste product.

**Publicly owned treatment works ("POTW")** means any facility for the treatment of pollutants owned by the State or any political subdivision thereof, any municipality, district, quasi-municipal corporation or other public entity.

**Septage** means, for the purposes of this permit, any waste, refuse, effluent sludge or other material removed from a septic tank, cesspool, vault privy or similar source which concentrates wastes or to which chemicals have been added. Septage does not include wastes from a holding tank.

**Time weighted composite** means a composite sample consisting of a mixture of equal volume aliquots collected over a constant time interval.

**Toxic pollutant** includes any pollutant listed as toxic under section 307(a)(1) or, in the case of sludge use or disposal practices, any pollutant identified in regulations implementing section 405(d) of the CWA. Toxic pollutant also includes those substances or combination of substances, including disease causing agents, which after discharge or upon exposure, ingestion, inhalation or assimilation into any organism, including humans either directly through the environment or indirectly through ingestion through food chains, will, on the basis of information available to the board either alone or in combination with other substances already in the receiving waters or the discharge, cause death, disease, abnormalities, cancer, genetic mutations, physiological malfunctions, including malfunctions in reproduction, or physical deformations in such organism or their offspring.

**Wetlands** means those areas that are inundated or saturated by surface or ground water at a frequency and duration sufficient to support, and that under normal circumstances do support, a prevalence of vegetation typically adapted for life in saturated soil conditions. Wetlands generally include swamps, marshes, bogs, and similar areas.

**Whole effluent toxicity** means the aggregate toxic effect of an effluent measured directly by a toxicity test.

# **BOARD DECISION**

## **MAINE POLLUTANT DISCHARGE ELIMINATION SYSTEM PERMIT AND WASTE DISCHARGE LICENSE**

### **FINDINGS AND FACT SHEET**

Date: **August 13, 2020**  
Revised **November 19, 2020**

MEPDES PERMIT: **ME0002771**  
WASTE DISCHARGE LICENSE: **W009200-6F-A-N**

NAME AND ADDRESS OF APPLICANT:

**NORDIC AQUAFARMS INC.  
159 High Street  
P.O. Box 283  
Belfast, Maine 04915**

COUNTY: **WALDO**

NAME AND ADDRESS WHERE DISCHARGE OCCURS:

**Route #1  
Belfast, Maine 04416**

RECEIVING WATER / CLASSIFICATION: **Belfast Bay, Class SB**

COGNIZANT OFFICIAL AND TELEPHONE NUMBER:

**Mr. Eric Heim, President**  
E-mail: [erik.heim@nordicaquafarms.com](mailto:erik.heim@nordicaquafarms.com)  
Tel: (207) 323-4911

**Ms. Elizabeth Ransom**  
E-mail: [Elizabeth.ransom@ransomenv.com](mailto:Elizabeth.ransom@ransomenv.com)  
Tel: (207) 772-2891

In compliance with the applicable provisions of *Pollution Control*, 38 M.R.S. §§ 411 – 424-B, *Water Classification Program*, 38 M.R.S. §§ 464 – 470, and *Federal Water Pollution Control Act*, Title 33 U.S.C. § 1251, and the Department of Environmental Protection (Department) rules, the Board of Environmental Protection (Board) has considered the application of Nordic Aquafarms Inc. (Nordic or the permittee) for a new Maine Pollutant Discharge Elimination System permit/Maine Waste Discharge License (MEPDES permit/WDL) with its supportive data, Department staff analysis, agency review comments, public hearing record, intervenor and public comments and other related materials on file and finds the following facts:

## 1. APPLICATION SUMMARY

- a. Application - On October 19, 2018, Nordic Aquafarms Inc. (Nordic or the permittee) submitted an application to the Department of Environmental Protection (Department) for a new Maine Pollutant Discharge Elimination System permit/Maine Waste Discharge License (MEPDES permit/WDL) for the monthly average discharge of 7.7 million gallons per day (MGD) of treated wastewater associated with a land based recirculating aquaculture system (RAS) to Belfast Bay, Class SB, in Belfast and Northport, Maine. See **Attachment A** of this Fact Sheet for a location map. Nordic proposes to rear Atlantic salmon from the egg life stage to market size fish weighing 10-12 pounds. At full production, the facility will be able to produce approximately 30,000 metric tons or 66 million pounds of fish per year. The permittee proposes to construct a fish processing facility (head-on, gutted) on-site.

On November 9, 2018, the Department formally accepted the application as complete and deemed the application acceptable for processing pursuant to 06-096 C.M.R. Chapter 2, *Rules Concerning the Processing of Applications and other Administrative Matters* (June 9, 2018).

At the request of Nordic, on June 20, 2019, the Board voted to assume jurisdiction of the MEPDES permit/WDL application and other applications. Between February 11 and February 14, 2020, the Board held an adjudicatory hearing in Belfast on Nordic's application. Except for several specific and limited matters for which it was held open, the record closed for public comment on the application on February 18, 2020.

On May 20, 2020, the Board held a deliberative session on the MEPDES permit/WDL application. On May 28, 2020, the record was reopened to gather additional information from Department staff and Nordic's consultant to ensure that the record was clear and accurate with regard to the far-field dilution factor and nitrogen limit calculations. Parties were given until June 12, 2020 to comment on the submissions.

**1. APPLICATION SUMMARY (cont'd)**

On August 13, 2020, the Board made the Department staff's draft recommended decision on MEPDES permit #ME0002771/Maine Waste Discharge License #W009200-6F-A-N available for a formal 30-day public comment period. On September 24, 2020, the Board of Environmental Protection, via its Twenty-First Procedural Order, granted certain commenters an extension of the comment period until October 5, 2020 to amend the relevant portion of their previous submittals, or file an additional comment, to correct or augment their comments regarding nutrient removal percentages. All comments received on the draft recommended Board Order were reviewed and considered by staff of the Department and the Board. A response to comments section can be found in this Fact Sheet.

- b. Title, Right or Interest - Pursuant to Department rules, Ch. 2 § 11(D), prior to acceptance of an application, an applicant must demonstrate to the Department's satisfaction sufficient title, right or interest (TRI) in all of the property that is proposed for development or use. An applicant must maintain sufficient TRI throughout the entire application processing period. Evidence of TRI may include deeds, easements, option agreements, and any other such evidence the Department deems acceptable to demonstrate sufficient TRI. When the project requires a submerged lands lease from the state, evidence must be supplied that the lease has been issued or that an application is pending.

Nordic submitted initial evidence of TRI in its October 19, 2018 MEPDES/WDL application, including purchase and sale agreements for easements and relevant parcels as well as evidence of a pending submerged lands lease application before the Bureau of Parks and Lands. The Department determined that this demonstrates sufficient TRI and accepted the application on November 9, 2018. Individuals and entities who later became intervenors to this proceeding submitted evidence challenging the sufficiency of TRI. In response to these filings, the Department requested additional information in a January 22, 2019, letter from Brian Kavanah. The letter requested confirmation that an easement option providing waterfront access included intertidal rights, specific locations of intake and outfall pipes, identification of any implicated property boundaries in the intertidal area, and evidence of sufficient rights to cross Route 1. The applicant proposed consolidating the existing application with Site Location of Development Act, Natural Resources Protection Act, and Air Emissions applications it planned to submit and petitioned for Board assumption of jurisdiction to review all of the applications. Intervenors again commented, submitting new challenges to the sufficiency of the evidence, including arguments concerning the ownership of the intertidal area and allegations that Nordic was withholding evidence that would undermine its claim of TRI.

**1. APPLICATION SUMMARY (cont'd)**

On May 17, 2019, Nordic submitted consolidated applications which contained additional evidence supportive of a demonstration of sufficient TRI for all four applications, including responses to the Department's January 22, 2019 letter. In a letter dated May 29, 2019 from Deputy Commissioner Melanie Loyzim, the Department requested "all information illustrating NAF's TRI that is in NAF's possession or control" including information the applicant had referenced but did not provide in prior submittals. Nordic provided a response to the Department on June 10, 2019. Intervenors submitted additional information regarding TRI on June 12, 2019. After considering all information received, the Department accepted the consolidated applications as complete for processing on June 13, 2019.

Pursuant to Chapter 2, the Department may return an application after it has been accepted as complete for processing if the Department determines that the applicant did not have, or no longer has, sufficient TRI. Invoking this provision, intervenors have requested multiple times that the Department, and then the Board, return the application for lack of TRI. The Department initially addressed these requests in its June 13, 2019 letter accepting the applications and the Board denied subsequent similar requests throughout the proceeding, including: in the 2<sup>nd</sup> Procedural Order (responding to a July 12, 2019 motion), in the 5<sup>th</sup> Procedural Order (responding to a filing entitled "Notice of NAF's Lack of [TRI]" based on a remand in a Bureau of Public Lands proceeding), in the 9<sup>th</sup> Procedural Order (following a request to return the applications based on statements made in an oral argument in related quiet title proceedings), in the 20<sup>th</sup> Procedural Order (following the Maine Supreme Court decision in *Tomasino v. Town of Casco*, 20 ME 96) in a vote following oral argument at an April 16<sup>th</sup> Board meeting (in response to February 14 & 18, 2020 motions to return the applications) and in a letter from the Presiding Officer dated August 27, 2020 (responding to the August 16, 2020 "Renewed Motion to Stay the Board's Proceedings or Dismiss Nordic's Applications). An appeal of the Board's April 16, 2020 decision was filed in Waldo County Superior Court and subsequently dismissed July 14, 2020.

**1. APPLICATION SUMMARY (cont'd)**

In its June 13, 2019 letter, the Department addressed and interpreted its TRI requirements under Chapter 2 as follows:

A determination that an applicant has demonstrated TRI sufficient for an application to be processed requires a showing of a legally cognizable expectation of having the power to use the site in the ways that would be authorized by the permits being sought. The purpose of this requirement is to allow the Department to avoid wasting its finite resources reviewing applications for projects that can never be built. If the applicant is unable to show a sufficient property interest in the site proposed for the project, pursuant to the TRI threshold requirement in Chapter 2 §11(D), the Department can return the application at the outset without devoting time and resources to its processing. In any TRI analysis under Chapter 2, the Department may look beyond an applicant's initial submissions and may request additional information and consider submissions of interested persons as necessary to judge whether adequate credible evidence has been submitted by the applicant and a sufficient showing of TRI has been made to warrant expending Department resources to process the application. The TRI provision cannot, however, be interpreted as compelling the Department to perform an exacting legal analysis of competing ownership claims to determine the ultimate ownership of the property. That ultimate conclusion can only be made by a court. Moreover, the Department rejects any such interpretation as directly counter to the purpose of the TRI provision and cannot afford to allow its permitting proceedings to be transformed into the equivalent of an administrative agency quiet title action. So long as the applicant is able to make a showing of TRI in the subject property that is sufficient to justify the processing of the application, the Department will generally consider this threshold requirement to be satisfied and move to evaluate the merits of the application.

With respect to the intertidal portion of the property proposed for use, the Department finds that the deeds and other submissions, including NAF's option to purchase an easement over the Eckrote property and the succession of deeds in the Eckrote chain of title, when considered in the context of the common law presumption of conveyance of the intertidal area along with an upland conveyance, constitute a sufficient showing of TRI for the Department to process and take action on the pending applications.

**1. APPLICATION SUMMARY (cont'd)**

The Intervenors raised the issues of whether the Purchase and Sale agreement between Janet and Richard Eckrote and Nordic applied to the intertidal zone. The Board examined the evidence pertaining to the Purchase and Sale Agreement and finds that the initial Purchase and Sale Agreement dated August 6, 2018, together with the March 3, 2019 letter from Ed Cotter of Nordic with an acknowledgement signed by Janet and Richard Eckrote extending the deadline for the closing and clarifying the intent of the parties to the easement as to its scope and location, are a sufficient demonstration of the scope of the easement agreement between the Eckrotes and Nordic for the purposes of processing the permit applications. The Board finds that the evidence reflects no dispute between the parties to the easement as to its scope or location.

The Board continues to concur with the Department's interpretation of Chapter 2's TRI provisions and its analysis with respect to the intertidal portion of the property proposed for use as set forth in the June 13, 2019 acceptance letter. As explained in the Department's acceptance letter, this conclusion is not an adjudication of property rights and does not grant legal ownership or right to use land. That determination can only be made by a Court. The Board has reviewed the evidence in the record and has again considered the arguments raised regarding TRI pursuant to the Department's Chapter 2 and its TRI provisions. Pursuant to the Board's interpretation of these TRI provisions, the Board finds that the applicant has made a sufficient showing of TRI to develop the property as proposed for the applications to be processed and decided. As the Department found in its June 13, 2019 acceptance letter, the deeds and other submissions, including Nordic's options to purchase, and the analysis of the chain of title remain unchanged and remain a sufficient showing for the Board to act on the applications.

- b. Source Description -The facility is proposed to consist of 10 buildings at full buildout. Buildings 1 and 2 will contain the grow-out modules, where the smolt will be raised to production size prior to being sent to processing. Both Building 1 and 2 will contain three grow-out modules each, giving a total of three upon completion of Phase 1, and six after Phase 2. Building 3 consists of Smolt 1 and 2. Smolt 1 will be constructed first and will raise the salmon from egg to smolt for building 1; Smolt 2 will be constructed in the second phase and will perform the same function for Building 2. Building 4, fish processing, will receive the salmon from the grow out modules and prepare them for market. Building 5 will be the central utility plant (CUP) which contains the main heating and cooling equipment needed for process temperature control along with backup generation for the



## 1. APPLICATION SUMMARY (cont'd)

entire facility. Building 6 will contain all the equipment needed to meet the facility's oxygen demands both through generation and storage. The administrative offices will be located in Building 7 and will contain all personnel not directly needed with the processing and support buildings. The water treatment plant, Building 8, will contain the intake and discharge water treatment systems, both for the freshwater and saltwater sources. Building 9 will be of a small gatehouse just North of the visitor center that will control access to the main site. Building 10 will be the original Belfast Water District (BWD) structure but will be renovated to serve as a visitor center for community and educational outreach. See **Attachment A** of this Fact Sheet for a site plan of the facility.

The proposed facility will be built in phases. Phase I will consist of infrastructure connection to the site, earth moving, construction of the smolt facility, the water and waste water treatment system, three grow-out modules, a processing facility and intake and discharge pipes. Nordic estimates construction of Phase I will take 12-15 months. Phase I will focus on the construction of the Smolt 1 facility, along with operational support facilities such as the seawater intake/discharge system, water treatment plant (WTP), CUP, oxygen generation, and administrative offices. Phase I construction will also include supporting infrastructure such as roadways, stormwater management systems and an electrical switchyard. Grow-out module construction will begin during Phase I, with the goal of three grow-out modules completed and ready for operation by the completion of the Phase I. Construction of the gatehouse will also be included in this phase of development.

Phase II will consist of constructing three additional grow-out modules. Nordic estimates Phase II construction will take 12 months. Phase II will begin after the completion of Phase I construction, commissioning, and start of operation. It will begin with an expansion of the overall area of impact, involving clearing of the southwest corner of the site in preparation of construction of Building 2. Accordingly, the erosion control and stormwater measures will be expanded to accommodate this area, as will supporting infrastructure such as access roads. Building 2, will contain the remaining three grow-out modules. Phase II will also include the renovation of the existing BWD building for the visitor center.

- c. Waste Water Treatment - The Nordic facility will use Recirculating Aquaculture System (RAS) technologies to reduce water consumption while rearing fish in a land-based facility. As a result of the reduced water consumption, elevated concentrations of waste metabolites develop. These elevated concentrations normally are at levels that can be treated and removed by basic RAS technologies and the concentrations are not so high that the fish are negatively impacted. Fish waste products that are treated with RAS technologies include BOD<sub>5</sub>, TSS, total phosphorus, total nitrogen and ammonia. Sanitary waste water generated at the facility will be conveyed to the municipal waste water treatment facility that is owned and operated by the City of Belfast. The discharge from the City of Belfast's waste water treatment facility is regulated via MEPDES permit #ME0101532.

## 1. APPLICATION SUMMARY (cont'd)

In a typical RAS, as Nordic has proposed here, 99% of the total flow is recirculated. As less than 1% is discharged per pass, concentrations for untreatable dissolved contaminants can be 100% higher than would be found in typical flow-through facilities. However, because much of the contaminants are waste solids, or are converted to waste solids by the biofiltration process, they can be extracted prior to discharge into the environment.

The process flow diagram in **Attachment B** of this Fact Sheet shows how water and contaminants that are discharged from independent RAS modules are combined and treated before the effluent is to be discharged into Belfast Bay.

The total tank volume in a module is 8,500 cubic meters or 2.45 million gallons. See **Attachment C** of this Fact Sheet. Water circulation is 2 x tank volumes per hour or 5 million gallons per hour. The water flows from the tank by gravity through several outlets at the bottom of the tank, removing feces/feed residues from the tank to the waste water treatment units, where it is mechanically treated by drum filters with 60 µm mesh screen size. In order to backwash the drum-filters, spray water is taken from the denitrification Moving Bed Bio-Reactors (MBBR) where total nitrogen concentrations are lowest. From the drum filters, the water is conveyed by gravity to the aerobic MBBR for biological treatment of ammonium to nitrate and reduction of organic matter.

A side-stream of approximately 8% of the recirculating flow is diverted on a loop after aerobic biological treatment through a second MBRR operating under anoxic conditions for denitrification of nitrate to free nitrogen. After mechanical/biological cleaning, the water passes over the central CO<sub>2</sub> degassing unit mounted above the pump. The CO<sub>2</sub> degassing unit consists of a countercurrent flow cascade based on a water distribution with crown nozzles and dimensioned at an air/water rate of 8:1. The suction effect by the ventilation in the cascade forms a small vacuum, which also removes any N<sub>2</sub> gas supersaturation. Alkalinity/pH control is done automatically via the Supervisory Control And Data Acquisition (SCADA) system which uses duplicate sensors to measure pH in the pump sump. If the values produced by the two sensors do not match, an alarm is triggered, and the dose is stopped.

The water from the pump sump is pumped back to the tank with Lykkegaard propeller pumps. Oxygen is added partly into the main water supply line and partly with high pressure oxygen cones.

## 1. APPLICATION SUMMARY (cont'd)

All water discharge pipework from the RAS comes directly from the internal water treatment system's mechanical filters and ( to a lesser extent) system overflow pipes. The pipes will all lead to the central WWTP. The WWTP provides treatment via:

1. Aerobic MBBR;
2. Chemical precipitation of total phosphorus;
3. Micro-Filtration (0.04  $\mu\text{m}$  pore size) in Membrane Bio-Reactors (MBR);
4. Sludge dewatering, decanter centrifuges, supernatant returned to biological treatment; and
5. Final liquid effluent ultra-violet (UV) sterilization prior to discharge.

All wastewater from the RAS units is conveyed directly to an equalization tank/pump station and into the primary biological treatment for additional total nitrogen (TN) removal. This biological treatment is based on proven MBBR technology. The biological treatment will be installed with capacity for variable recirculation flow from the aerobic to the pre-anoxic MBBR for N removal. Biological phosphorous removal will occur in practice via aerobic/anoxic MBBRs used and will be designed for removal only by chemical precipitation/MBR removal. For final polishing, water from the biological treatment passes through STERAPORE Hollow Fiber Membrane Bio-Reactors with in-line addition of ferric chloride for phosphorus precipitation. Here, fine solids removal takes place with 0.04  $\mu\text{m}$  mesh membranes (Micro Filtration). The MBR units are equipped with automatic Clean-in Place (CIP) systems.

Captured sludge from the MBR treatment is pumped to the sludge thickening unit for reduction of sludge volume. Sludge thickening consists of decanter centrifuges, provided by Alfa Laval. Separation takes place in a horizontal, cylindrical bowl equipped with a screw conveyor. The sludge enters the bowl through a stationary inlet tube and is accelerated smoothly by an inlet distributor. The centrifugal force that results from the rotation then causes sedimentation of the solids on the wall of the bowl.

The conveyor rotates in the same direction as the bowl, but slightly slower, moving the solids towards the conical end of the bowl. The solids leave the bowl through the solids discharge openings into the casing. Separation takes place throughout the entire length of the cylindrical part of the bowl and the clarified liquid leaves the bowl by flowing over adjustable plate dams into the casing. The liquid fraction is returned to the MBBR.

With the treatment system described above, the permittee anticipates removal rates as follows:

Biochemical oxygen demand & total suspended solids (BOD & TSS) – 99%;

Total nitrogen – 85%; and

Total phosphorus – 99%.

## 1. APPLICATION SUMMARY (cont'd)

The treated wastewater will be discharged to the Belfast Bay via a 36" diameter outfall with the terminus of the pipe located approximately 3,600 feet offshore in approximately 35 feet of water at mean low tide. See **Attachment D** of this Fact Sheet. The end of the pipe will be fitted with a three-port diffuser, each 50-feet on center. The diffusers will be fitted with flexible duckbill style valves that will reduce flow area to maintain a greater exit velocity from the ports which will enhance mixing with the receiving water.

During the February 11-14, 2020 adjudicatory hearing held by the Board in the City of Belfast, intervenors raised questions or concerns about topics including modeling of the discharge and the resulting dilution factors associated with the discharge as well as the potential impacts to the receiving water from the discharge of nitrogen, temperature and pathogens. Each of these topics are discussed in detail in Section 5 of this Fact Sheet.

## 2. CONDITIONS OF PERMITS

*Conditions of licenses*, 38 M.R.S. § 414-A, requires that the effluent limitations prescribed for discharges, including, but not limited to, effluent toxicity, require the application of best practicable treatment (BPT), be consistent with the federal Clean Water Act, and ensure that the receiving waters attain the State water quality standards as described in Maine's Surface Water Classification System. In addition, *Certain deposits and discharges prohibited*, 38 M.R.S. § 420, and Department rule *Surface Water Toxics Control Program*, 06-096 C.M.R. ch. 530, require the regulation of toxic substances not to exceed levels set forth in *Surface Water Quality Criteria for Toxic Pollutants*, 06-096 C.M.R. ch. 584, and ensure safe levels for the discharge of toxic pollutants such that existing and designated uses of surface waters are maintained and protected.

## 3. RECEIVING WATER QUALITY STANDARDS

*Classification of estuarine and marine waters*, 38 M.R.S. § 469(6), classifies all tidal waters in Waldo County (which includes the area of the discharge) as Class SB waters. *Standards for classification of estuarine and marine waters*, 38 M.R.S. § 465-B(2), describes the standards for Class SB waters as follows:

- A. *Class SB waters must be of such quality that they are suitable for the designated uses of recreation in and on the water, fishing, aquaculture, propagation and harvesting of shellfish, industrial process and cooling water supply, hydroelectric power generation, navigation and as habitat for fish and other estuarine and marine life. The habitat must be characterized as unimpaired.*
- B. *The dissolved oxygen content of Class SB waters may not be less than 85% of saturation. Between April 15th and October 31st, the number of enterococcus bacteria in these waters may not exceed a geometric mean of 8 CFU per 100 milliliters in any 90-day interval or 54 CFU per 100 milliliters in more than 10% of the samples in any 90-day interval. The number of total coliform bacteria or other specified indicator organisms in samples representative of the waters in shellfish harvesting areas may not exceed the criteria*

### 3. RECEIVING WATER QUALITY STANDARDS (cont'd)

*recommended under the National Shellfish Sanitation Program, United States Food and Drug Administration.*

- C. *Discharges to Class SB waters may not cause adverse impact to estuarine and marine life in that the receiving waters must be of sufficient quality to support all estuarine and marine species indigenous to the receiving water without detrimental changes in the resident biological community. There may be no new discharge to Class SB waters that would cause closure of open shellfish areas by the Department of Marine Resources. For the purpose of allowing the discharge of aquatic pesticides approved by the department for the control of mosquito-borne diseases in the interest of public health and safety, the department may find that the discharged effluent will not cause adverse impact to estuarine and marine life as long as the materials and methods used provide protection for nontarget species. When the department issues a license for the discharge of aquatic pesticides authorized under this paragraph, the department shall notify the municipality in which the application is licensed to occur and post the notice on the department's publicly accessible website.*

### 4. RECEIVING WATER QUALITY CONDITIONS

*The State of Maine 2016 Integrated Water Quality Monitoring and Assessment Report*, prepared by the Department pursuant to Sections 303(d) and 305(b) of the federal Clean Water Act, lists Belfast Bay in:

- Category 4-A(b): Estuarine and Marine Waters With An Impaired Use – TMDL Completed (Bacteria from Combined Sewer Overflows). The City of Belfast has two CSOs that are causing or contributing to the impairment.
- Category 5D – Estuarine and Marine Waters Impaired by Legacy Pollutants due to elevated levels of PCBs and other persistent, bioaccumulating substances in tomalley.

The Maine Department of Marine Resources (MDMR) Pollution Area #32, Belfast Bay, is listed as closed to the harvesting of shellfish. The impairment is listed as elevated fecal coliform bacteria. See **Attachment E** of this Fact Sheet for a MDMR map depicting the closure area.

The Department has made a best professional judgment (BPJ) determination based on information gathered to date and the information in this Fact Sheet that, as permitted, the discharge will not cause or contribute to the failure of the receiving water to meet the standards of its ascribed classification and the designated uses of the waterbody will continue to be maintained and protected. If future modeling or ambient water quality monitoring determines the discharge is causing or contributing to the non-attainment of standards, this permit will be re-opened pursuant to Special Condition O, *Reopening of The Permit For Modifications*, to impose more stringent limitations to meet water quality standards.

## 5. EFFLUENT LIMITATIONS & MONITORING REQUIREMENTS

- a. Flow: This permitting action is establishing a monthly average flow limitation of 7.7 MGD for Outfall #001A based on information provided by the permittee.
- b. Dilution Factors: *Enforcement generally* 38 M.R.S. § 451, states in relevant part:

*After adoption of any classification by the Legislature for surface waters or tidal flats or sections thereof, it is unlawful for any person, firm, corporation, municipality, association, partnership, quasi-municipal body, state agency or other legal entity to dispose of any pollutants, either alone or in conjunction with another or others, in such manner as will, after reasonable opportunity for dilution, diffusion or mixture with the receiving waters or heat transfer to the atmosphere, lower the quality of those waters below the minimum requirements of such classifications, or where mixing zones have been established by the department, so lower the quality of those waters outside such zones, notwithstanding any exemptions or licenses which may have been granted or issued under sections 413 to 414-B.*

*The department may establish a mixing zone for any discharge at the time of application for a waste discharge license. The department shall attach a description of the mixing zone as a condition of a license issued for that discharge. After opportunity for a hearing in accordance with section 345-A, the department may establish by order a mixing zone with respect to any discharge for which a license has been issued pursuant to section 414 or for which an exemption has been granted by virtue of section 413, subsection 2.*

*The purpose of a mixing zone is to allow a reasonable opportunity for dilution, diffusion or mixture of pollutants with the receiving waters before the receiving waters below or surrounding a discharge will be tested for classification violations. In determining the extent of any mixing zone to be established under this section, the department may require from the applicant testimony concerning the nature and rate of the discharge; the nature and rate of existing discharges to the waterway; the size of the waterway and the rate of flow therein; any relevant seasonal, climatic, tidal and natural variations in such size, flow, nature and rate; the uses of the waterways in the vicinity of the discharge, and such other and further evidence as in the department's judgment will enable it to establish a reasonable mixing zone for such discharge. An order establishing a mixing zone may provide that the extent thereof varies in order to take into account seasonal, climatic, tidal and natural variations in the size and flow of, and the nature and rate of, discharges to the waterway.*

## 5. EFFLUENT LIMITATIONS & MONITORING REQUIREMENTS (cont'd)

*Where no mixing zones have been established by the department, it is unlawful for any person, corporation, municipality or other legal entity to dispose of any pollutants, either alone or in conjunction with another or others, into any classified surface waters, tidal flats or sections thereof, in such manner as will, after reasonable opportunity for dilution, diffusion, mixture or heat transfer to the atmosphere, lower the quality of any significant segment of those waters, tidal flats or sections thereof, affected by such discharge, below the minimum requirements of such classification, and notwithstanding any licenses which may have been granted or issued under sections 413 to 414-B.*

*Surface Water Toxics Control Program, 06-096 C.M.R ch. 530, § 4(A)(2)(a) (calculation of dilution factors) states in part*

*For discharges to the ocean, dilution must be calculated as near-field or initial dilution, or that dilution available as the effluent plume rises from the point of discharge to its trapping level, at mean low water level and slack tide for the acute exposure analysis, and at mean tide for the chronic exposure analysis using appropriate models determined by the Department such as MERGE, CORMIX or another predictive model.*

### Modeling for Near-field and Far-field Dilution

Intervenors have commented the CORMIX and ADCIRC models are not appropriate tools to determine mixing factors at or near the discharge site because of their inability to fully take into account the complexity of the site with respects to winds, current speeds and direction differentiated by depth, the local tide regime, and the local finer scale shoreline configuration.

The United States Environmental Protection Agency (USEPA) supports the use of the CORMIX model for calculating near-field dilution factors. Page 76 of the *USEPA Technical Support For Water Quality Based Toxics Control, March 1991*, states in relevant part;

*The first model, CORMIX may be the most useful to regulators since it is an expert system that guides the user in selecting an appropriate modeling strategy for rivers or estuaries.*

*CORMIX is a series of software elements for the analysis of a submerged buoyant or nonbuoyant discharge containing conventional or toxic pollutants and entering into stratified or unstratified watercourses, with emphasis on the geometry and dilution characteristics of the initial mixing zone.*

## 5. EFFLUENT LIMITATIONS & MONITORING REQUIREMENTS (cont'd)

### Near-Field Dilution

Near-field dilution factors are applicable to pollutants that have the potential for an immediate adverse effect on the flora or fauna of a marine ecosystem. For example, marine organisms react to elevated levels of toxic pollutant such as total metals with hours or days of being exposed. Therefore, estimating acute and chronic dilution factors with a steady state model such as the CORMIX model is supported by Department rules and USEPA technical support documents.

In a letter dated August 14, 2019, to the Department, Nordic stated it had utilized the CORMIX model to determine the near-field dilution factors for the proposed discharge from the Nordic facility. The input parameters included, but were not limited to, a full permitted flow rate of 7.7 MGD that would be discharged via an outfall pipe measuring 36 inches in diameter with a multi-port diffuser discharging at approximately 35 feet below mean low water approximately 3,600 feet from the shoreline along with a 15-minute time of travel. The applicant calculated worst case near-field dilution factors of 10:1 (acute) and 15:1 (chronic).

### Far-field dilution

Far-field dilution factors are applicable to pollutants that have the potential for a more subtle and or systemic types of effects on the flora or fauna of a marine ecosystem, or pollutants that exert their influence on broader time scales. For example, biochemical oxygen demand (BOD<sub>5</sub>) decays over time and takes five days after being discharged to exert its implied influence on ambient dissolved oxygen. Eutrophication associated with excessive nitrogen loadings happens on significantly broader spatial and time scales in marine systems such as Belfast Bay, due in large part to the very dynamic nature of the bay.

Unlike the CORMIX model that is supported by Department rules and USEPA technical support documents for estimating near-field acute and chronic dilution factors, there currently are no state or federal rules or statutes that designate acceptable methodologies to model far-field dilution. Therefore, modeling personnel must use BPJ to select modeling tools that are most appropriate for a particular receiving water and discharge characteristics.



## 5. EFFLUENT LIMITATIONS & MONITORING REQUIREMENTS (cont'd)

Title 38 M.R.S. § 451 provides some guidance regarding dilution factors that may be considered by the Department:

*In determining the extent of any mixing zone to be established under this section, the department may require from the applicant testimony concerning the nature and rate of the discharge; the nature and rate of existing discharges to the waterway; the size of the waterway and the rate of flow therein; any relevant seasonal, climatic, tidal and natural variations in such size, flow, nature and rate; the uses of the waterways in the vicinity of the discharge, and such other and further evidence as in the department's judgment will enable it to establish a reasonable mixing zone for such discharge.*

For this permitting action, Nordic utilized a hydrodynamic model referred to as the ADvanced CIRculation (ADCIRC) model to estimate the far-field dilution factors for the discharge to Belfast Bay. The ADCIRC model was originally developed for coastal flood hazard studies in the larger Penobscot Bay and has many of the dynamic physical attributes of the bay already built into the model. Nordic evaluated a particle tracking output from the model to evaluate the far-field dilution factor in close proximity to the discharge over 4 tide cycles (two days).

Department staff examined Nordic's application materials and pre-filed testimony, including Figure 2. *Time series of areal dilution distribution within region containing diluted effluent with median age between 1.5 days and 2.5 days old*, in the November 3, 2019 memorandum from Nathan Dill to Nordic Aquafarms (Nordic Pre-Filed Direct Testimony, Exhibit 23, Figure 2). According to the Nordic memorandum, the green line on Figure 2 represents "50% of the 2-day old area has dilution greater than about 300 ( $10^{2.5}$ )."  
The Department staff initially mistakenly interpreted Figure 2 and associated text in Nordic's November 3, 2019 memorandum to suggest that the mean (average) of median values resulted in a far-field dilution factor of 300:1.

On May 19, 2020, Department staff received a communication from Nordic's consultant indicating the Department had misinterpreted information presented in the Figure 2 graph. Department staff thereafter reconsidered the appropriate far-field dilution factor and revised their analysis of Nordic's proposed discharge accordingly. Without access to the data underlying Figure 2, which had not been submitted into the record prior to the Board's May 20, 2020 deliberative session, Department staff estimated the far-field dilution factor to be 530:1 by scaling daily measurements shown on Figure 2 and arithmetically meaning the results. Staff discussed this revised analysis with the Board at a deliberative session on May 20, 2020.

## 5. EFFLUENT LIMITATIONS & MONITORING REQUIREMENTS (cont'd)

As explained by Department staff during the Board's deliberative session, the Department's practice is to use a more normalized condition, such as the mean, for far-field dilution factor purposes. The staff summarized the rationale for the Department's use of a more normalized condition in this context as it more accurately reflects the impact (or lack thereof) of nitrogen on the receiving water given the longer response times (3-14 days) associated with nitrogen discharges.

In the Seventeenth Procedural Order, the Presiding Officer allowed a limited reopening of the record for the submission of the pre-deliberation communication from Nordic with Department staff, the data underlying Figure 2, and comments by the intervenors on the appropriate far-field dilution factor and the underlying data. Staff submitted the pre-deliberation communication into the record on May 29, 2020. Nordic submitted the underlying data into the record on May 29, 2020.

Once the Department received the data underlying Figure 2 from Nordic into the record, the Department conducted its own statistical evaluation of the appropriate far-field dilution factor, which allowed it to refine its earlier estimate of 530:1. Based on Department staff's review of the Nordic application and pre-filed materials, and the data utilized to generate the graphs in including Figure 2. *Time series of areal dilution distribution within region containing diluted effluent with median age between 1.5 days and 2.5 days old*, and the comments submitted by intervenors, the Department staff determined that a far-field dilution factor of approximately 532:1 is most appropriate for assessing the impact of Nordic's proposed discharge on dissolved oxygen in the receiving waters as further described in Section 5(d) below. The Board concurs with this determination.

For potential impacts to the closest currently mapped (2019) eelgrass bed located approximately 4 kilometers (2.5 miles) to the southwest of the proposed discharge along the southern shore of Northport as mapped by the Department (see Figure 5 on the attached aerial photograph entitled *Fig.1: Belfast Bay and Penobscot Bay*) in Attachment F of this Fact Sheet, the dilution factor of 1,500:1 as further described in Section 5(d) below was based on the Department's BPJ after review of the Nordic's modeling contained in their application.

Intervenors submitted comments on June 12, 2020. Both the pre-deliberation communication from Nordic and the data underlying Figure 2 indicated that a mean of the median values of 532:1 is most representative of the far-field dilution factor for the proposed discharge from the Nordic facility. Intervenor Upstream Watch submitted comments from Gary Gulezian, John Krueger, Kyle Aveni-Deforge, and Sean Beacham. These comments asserted that: (1) additional interpretation of underlying data indicates a far-field dilution factor ranging from 300:1 to 451:1 is a reasonable interpretation of the underlying data of Figure 2; and (2) additional ambient water quality data such as water column temperature, density, current speeds and direction are needed to verify modelling

## 5. EFFLUENT LIMITATIONS & MONITORING REQUIREMENTS (cont'd)

results to date as well as additional testing of ambient nitrogen and dissolved nitrogen levels to determine more accurate background levels and degree of stratification. Intervenor Northport Village Corporation (NVC) also submitted comments arguing that Nordic should be required to hold public meetings so the residents of the NVC, City of Belfast, Town of Searsport, Town of Islesboro, and the Town of Northport can review and discuss the economic and social benefits and tradeoffs from the proposed project.

Based on Department staff's review and analysis of Nordic's application, testimony and modeling and the evidence and comments submitted by the intervenors, the Board finds that the proposed near-field factors (acute 10:1, chronic 15:1) and far-field dilution factors (532:1 and 1,500:1) are appropriate and will be utilized for the discharge. The Board finds use of the CORMIX model and the ADCIRC model are supported by Department rule and the USEPA for estimating the geometry and dilution characteristics of the receiving waters and the resulting dilution factors are based on a sound scientific rationale and meet the dilution licensing criteria established in 38 M.R.S., § 451 and 06-096 CMR ch. 530.

Special Condition F, *Dye Study*, of this permit requires the permittee to conduct a dye study once operations have commenced and a steady state flow of 7.7 MGD has been achieved. The information derived from this dye study will assist the Department in further assessing the hydrodynamics of the receiving water and dilution factors associated with the discharge. See section 7 of this Fact Sheet for more information on the dye study requirements.

On June 12, 2020, the NVC commented that the parties and the public should be given additional opportunity to present evidence regarding the economic and social benefits and tradeoffs of Nordic's facility. Nevertheless, because the Board finds that Nordic's discharge, as permitted, will not lower the water quality of Belfast Bay, the need to make a finding that issuing this permit is necessary to achieve important economic or social benefits to the State has not been triggered. See Section 5(d) below regarding antidegradation and 38 M.R.S. § 464(4)(F)(5). There is therefore no need for the Department to provide additional opportunity for public participation or comment relating to the economic or social benefits of Nordic's project to the State.

### c. Biochemical Oxygen Demand (BOD<sub>5</sub>) and Total Suspended Solids (TSS):

*Classifications of estuarine and marine waters*, 38 M.R.S. § 469, states that all estuarine and marine waters lying within the boundaries of coastal counties of the State of Maine and that are not otherwise classified are Class SB waters. See also 38 M.R.S. § 469(6) (regarding waters of Waldo County).

## 5. EFFLUENT LIMITATIONS & MONITORING REQUIREMENTS (cont'd)

*Standards for classification of estuarine and marine waters, 38 M.R.S. § 465-B(2), states in relevant part:*

*Class SB waters. Class SB waters shall be the 2nd highest classification.*

- B. The dissolved oxygen content of Class SB waters may not be less than 85% of saturation.*
- C. Discharges to Class SB waters may not cause adverse impact to estuarine and marine life in that the receiving waters must be of sufficient quality to support all estuarine and marine species indigenous to the receiving water without detrimental changes in the resident biological community.*

*Classification of Maine Waters, 38 M.R.S. § 464 (4) (F)(3), states in relevant part:*

*The department may only issue a discharge license pursuant to section 414-A or approve water quality certification pursuant to the Federal Water Pollution Control Act, Section 401, Public Law 92-500, as amended, if the standards of classification of the water body and the requirements of this paragraph are met. The department may issue a discharge license or approve water quality certification for a project affecting a water body in which the standards of classification are not met if the project does not cause or contribute to the failure of the water body to meet the standards of classification.*

*38 M.R.S. § 464 (4)(C) states:*

*Where natural conditions, including, but not limited to, marshes, bogs and abnormal concentrations of wildlife cause the dissolved oxygen or other water quality criteria to fall below the minimum standards specified in sections 465, 465-A and 465-B, those waters shall not be considered to be failing to attain their classification because of those natural conditions.*

*Conditions of licenses, 38 M.R.S. § 414-A(1)(D), states in relevant part (emphasis added):*

*The discharge will be subject to effluent limitations that require application of the best practicable treatment. "Effluent limitations" means any restriction or prohibition including, but not limited to, effluent limitations, standards of performance for new sources, toxic effluent standards and other discharge criteria regulating rates, quantities and concentrations of physical, chemical, biological and other constituents that are discharged directly or indirectly into waters of the State. "Best practicable treatment" means the methods of reduction, treatment, control and handling of pollutants, including process methods, and the application of best conventional pollutant control technology or best available technology economically achievable, for a category or class of discharge sources that the department determines are best calculated to protect and improve the quality of the receiving water and that are consistent with the requirements of the Federal*

## 5. EFFLUENT LIMITATIONS & MONITORING REQUIREMENTS (cont'd)

*Water Pollution Control Act, as amended, and published in 40 Code of Federal Regulations. If no applicable standards exist for a specific activity or discharge, the department must establish limits on a case-by-case basis using best professional judgment, after consultation with the applicant and other interested parties of record. In determining best practicable treatment for each category or class, the department shall consider the existing state of technology, the effectiveness of the available alternatives for control of the type of discharge and the economic feasibility of such alternatives.*

BOD<sub>5</sub> is a measurement of dissolved oxygen that is used by aerobic microorganisms when decomposing organic matter in water. Elevated BOD<sub>5</sub> discharged into a receiving water can cause the ambient dissolved oxygen to be depleted. TSS are solids in water that can be trapped by a filter. Elevated levels of TSS can settle to the bottom of receiving water and impact the resident biological community.

Currently, there are no state or federally promulgated best practicable treatment (BPT) numeric standards for BOD<sub>5</sub> and TSS for land-based RAS facilities. In 2002, the USEPA promulgated standards for RAS facilities based on narrative best management practices (BMPs) controls but opted not to establish numerical standards for BOD<sub>5</sub> and TSS at this time. However, the Department has historically been more stringent than the federally promulgated standards and has established numeric limitations for both parameters. The Department has issued MEPDES permits/WDL for other RAS facilities establishing monthly average and daily maximum concentration limits of 30 mg/L and 50 mg/L respectively for BOD<sub>5</sub> and TSS based on Department BPJ of BPT for RAS facilities. These limits were based on BPT recommendations included in USEPA's 2002 proposed draft National Effluent Guidelines for TSS for re-circulated fish hatchery wastewater receiving a secondary level of treatment and the Department's long-standing view of the relationship between TSS and BOD<sub>5</sub>. For the proposed discharge from the Nordic facility, mass limits will be calculated based on the monthly average flow limit of 7.7 MGD, the applicable concentration limits of 30 mg/L and 50 mg/L (based on the Department's historic practice and BPJ) and a conversion factor of 8.34 lbs/gal for water.

The limits are therefore calculated as follows:

Monthly average:  $(7.7 \text{ MGD})(30 \text{ mg/L})(8.34 \text{ lbs/gal}) = 1,926 \text{ lbs/day}$ ; and

Daily maximum:  $(7.7 \text{ MGD})(50 \text{ mg/L})(8.34 \text{ lbs/gal}) = 3,211 \text{ lbs/day}$ .

The Department staff modeled the impact of the BPT discharge levels calculated above for BOD<sub>5</sub> and TSS on the ambient dissolved oxygen and determined the discharge would not have a discernable influence on ambient dissolved oxygen. The proposed discharge of BOD<sub>5</sub> at 30 mg/L has the potential to increase ambient BOD<sub>5</sub> concentrations by up to 0.1 mg/L, based on a far-field dilution factor of 532:1 ( $30 \text{ mg/L}/532 = 0.057 \text{ mg/L}$ ). BOD is exerted at an approximate rate of 20% per day, which would suggest a relative influence on dissolved oxygen of approximately 0.011 mg/L ( $0.057 \text{ mg/L}/5 = 0.011 \text{ mg/L}$ ). This

## 5. EFFLUENT LIMITATIONS & MONITORING REQUIREMENTS (cont'd)

degree of influence is significantly less than what could be measured within a reliable degree of accuracy. Dissolved oxygen monitoring instrumentation is only accurate to within plus or minus 0.1 mg/L.

According to data collected by Nordic and included in its MEPDES permit application and data collected by the Department in the summer of 2019, there are areas of naturally occurring dissolved oxygen levels that do not attain the Class SB 85% saturation standard. The pipe will discharge at approximately 35 feet below the mean low water mark and will be fitted with a multiport diffuser designed to enhance mixing with the receiving water. The discharge will tend to be buoyant due to the freshwater component of the discharge. The pycnocline is the area of separation between two different densities of water due to changes in salinity and temperature gradients. Areas above the pycnocline tend to be better mixed due to wave action and water below the pycnocline tend to be hydraulically isolated due to greater density. The Department's water quality modelling engineer and marine biologist have assessed this information and based on their review and analysis, concluded that the impact to the naturally occurring area of dissolved oxygen saturation levels of less than 85% will not be measurable given the buoyancy of the proposed discharge.

Nordic's application for a MEPDES permit states that if the maximum efficiencies of the wastewater treatment facility are realized, the discharge concentration of BOD<sub>5</sub> and TSS will be as low 6 mg/L, representing a 99% removal rate for both parameters.

Based on Department staff's review and analysis, the Board finds that establishing an application of BPT-based limitations for BOD<sub>5</sub> and TSS will enable Nordic's discharge to meet the dissolved oxygen standard licensing criteria of 85% saturation and will not cause or contribute to failure of the receiving water to meet the standards of its assigned classification.

- d. Total Nitrogen (TN) – *Classification of Maine Waters*, 38 M.R.S. § 464, sets forth provisions governing the states antidegradation policy and states in relevant part:

*3. The department may only issue a discharge license pursuant to section 414-A or approve water quality certification pursuant to the Federal Water Pollution Control Act, Section 401, Public Law 92-500, as amended, if the standards of classification of the water body and the requirements of this paragraph are met. The department may issue a discharge license or approve water quality certification for a project affecting a water body in which the standards of classification are not met if the project does not cause or contribute to the failure of the water body to meet the standards of classification.*

*5. The department may only issue a discharge license pursuant to section 414-A or approve water quality certification pursuant to the United States Clean Water Act, Section 401, Public Law 92-500, as amended, which would result in lowering the existing quality of any water body after making a finding, following opportunity for public participation, that the action is necessary to achieve important economic or social benefits to the State and when*

## 5. EFFLUENT LIMITATIONS & MONITORING REQUIREMENTS (cont'd)

*the action is in conformance with subparagraph (3). That finding must be made following procedures established by rule of the board.*

*Conditions of licenses, 38 M.R.S. §414-A 1(D) states in relevant part:*

*The Department shall issue a license for a discharge of pollutants only if it finds that:*

*The discharge will be subject to effluent limitations that require application of the best practicable treatment. "Effluent limitations" means any restriction or prohibition including, but not limited to, effluent limitations, standards of performance for new sources, toxic effluent standards and other discharge criteria regulating rates, quantities and concentrations of physical, chemical, biological and other constituents that are discharged directly or indirectly into waters of the State. "Best practicable treatment" means the methods of reduction, treatment, control and handling of pollutants, including process methods, and the application of best conventional pollutant control technology or best available technology economically achievable, for a category or class of discharge sources that the department determines are best calculated to protect and improve the quality of the receiving water and that are consistent with the requirements of the Federal Water Pollution Control Act, as amended, and published in 40 Code of Federal Regulations. If no applicable standards exist for a specific activity or discharge, the department must establish limits on a case-by-case basis using best professional judgment, after consultation with the applicant and other interested parties of record. In determining best practicable treatment for each category or class, the department shall consider the existing state of technology, the effectiveness of the available alternatives for control of the type of discharge and the economic feasibility of such alternatives.*

Nitrogen is generally the limiting nutrient for primary productivity in marine waters. Discharges of excess quantities of immediately bioavailable nitrogen can cause algal blooms in the receiving waters, which can lead to negative impacts to dissolved oxygen levels. Immediately bioavailable nitrogen typically consists of dissolved inorganic forms, including nitrate ( $\text{NO}_3^-$ ), nitrite ( $\text{NO}_2^-$ ), and ammonium ( $\text{NH}_4^+$ ). Total kjeldahl nitrogen (TKN) is the sum of organic nitrogen, ammonia ( $\text{NH}_3$ ), and ammonium ( $\text{NH}_4^+$ ). To calculate Total Nitrogen (TN), the concentrations of nitrate and nitrite are determined and added to TKN. With the exception of ammonia, nitrogen is not acutely toxic; thus, at this time, the Department considers a far-field dilution model to be most appropriate when evaluating the more systemic types of influences associated with nitrogen in the marine environment.

Currently there are no state or federally promulgated BPT standards for land-based RAS facilities and the State of Maine has not promulgated numeric ambient water quality criteria for TN. Since 2015, on a case-by-case basis, Department staff have completed reasonable potential (RP) analyses upon renewal of wastewater discharge licenses for those

## 5. EFFLUENT LIMITATIONS & MONITORING REQUIREMENTS (cont'd)

facilities that discharge nitrogen directly to marine waters of the state. To date, the Department's RP analyses have generally utilized two TN threshold values to address aquatic life use of Maine's marine waters that the Department staff believe are appropriate here and are as follows:

- 0.32 mg/L for protection of eelgrass, when historically mapped as present within close proximity to the discharge in question; and
- 0.45 mg/L for protection of dissolved oxygen, when eelgrass has not been historically mapped within close proximity to the discharge in question.

The Board finds that using these threshold values is consistent with the Department's past practices and is appropriate for Nordic's permit.

The Department's definition of "close proximity" with regard to eelgrass has been eelgrass located approximately 0.5 km from the wastewater outfall, or by BPJ based on known eelgrass resources. The 0.32 mg/L TN threshold value the Department currently uses as the threshold value for the protection of eelgrass is a concentration used regionally by USEPA permitting staff. The USEPA decision to use 0.32 mg/L was due to its numerical midpoint between 0.34 mg/L, a concentration deemed protective of eelgrass by the Massachusetts Estuary Project, and 0.30 mg/L, an average concentration from the lower Piscataqua River where the Department observed epiphytic growth on eelgrass that resulted in a 2012 impaired waters listing due to eelgrass loss. The TN threshold value of 0.45 mg/L used for the protection of dissolved oxygen originates from a New Hampshire Department of Environmental Services (NH DES) guidance document for the Great Bay estuary (NH DES 2009), and was utilized in an EPA-issued wastewater discharge license in the Taunton River estuary in Massachusetts (EPA 2015).

Although eelgrass beds were historically (1992 and 2003) mapped as close to Nordic's discharge as 0.5 kilometers (0.3 miles), based on a 2019 summer Department survey, the Board finds the nearest eelgrass to the proposed discharge is currently approximately 4 kilometers (2.5 miles) to the southwest along the southerly shore of Northport. See **Attachment F** of this Fact Sheet. Given the absence of mapped eelgrass in close proximity to the Nordic discharge and the moderately high light attenuation occurring in the water column as measured by the Department at nearby eelgrass habitat based on suspended solids and dissolved organic matter, the Department is utilizing a critical nitrogen threshold value of 0.45 mg/L and a far-field dilution factor of 532:1 to evaluate the impact of the discharge on dissolved oxygen in the vicinity of the discharge location. For the closest



## 5. EFFLUENT LIMITATIONS & MONITORING REQUIREMENTS (cont'd)

eelgrass bed, the Department is utilizing a critical nitrogen threshold value of 0.32 mg/L and a dilution factor of 1,500:1 to evaluate the impact on the eelgrass bed based on the Department's BPJ after review of the Nordic's modeling contained in their application materials. Both environment response indicators are being evaluated for total nitrogen given the geographic differences in the dilution factors associated with each environmental response indicator. The Department staff utilizes a weight of evidence approach to determine attainment of water quality standards and places a greater weight on ambient water chemistry and biological data, including dissolved oxygen, pH, and chlorophyll *a* to determine whether the discharge, if permitted, will cause or contribute to violations of water quality.

The State of Maine's antidegradation policy states that water quality that exceeds the minimum applicable standards will be managed by the Department for the environmental, economic, and social benefit of the State. *See* 38 M.R.S. §§414-A(1)(C), 464(4)(F)(5). Where a new or increased discharge is proposed, the Department determines whether the discharge will result in a lowering of existing water quality.

### Discussion of Antidegradation

- New discharge means a discharge that does not now exist or that is not currently licensed.
- Increased discharge means a discharge that would add one or more new pollutants to an existing effluent, increase existing levels of pollutants in an effluent, or cause an effluent to exceed one or more of its current licensed discharge flow or effluent limits, after the application of applicable best practicable treatment technology, as defined at 38 M.R.S. § 414-A(1)(D), or new source performance standards to the discharge.
- Existing water quality means the water quality that would exist under critical water quality conditions. Critical water quality conditions include, but are not limited to, conditions of low flow, high water temperature, maximum loading from point source and non-point source discharges, and conditions of acute and chronic effluent toxicity.

In making a determination as to whether a new or increased discharge will result in a lowering of existing water quality pursuant to the statutory standard, the Department staff generally considers the following on a case-by-case basis consistent with its historical practice and best experience and judgment as reflected in its non-binding Antidegradation Waste Discharge Program Guidance dated June 13, 2001 developed in consultation with the USEPA:

- The predicted change in ambient water quality, concentrations of chemical pollutants, or mass loading of pollutants under critical water quality conditions.

## 5. EFFLUENT LIMITATIONS & MONITORING REQUIREMENTS (cont'd)

- The predicted consumption of the remaining assimilative capacity of the receiving water. The remaining assimilative capacity is the increment of existing water quality above the minimum standards of the assigned classification under critical water quality conditions.
- The predicted change in the ability of the receiving water to support aquatic life and to meet applicable aquatic life and habitat criteria.
- The possible additive or synergistic effects of the discharge in combination with other existing discharges.
- The cumulative lowering over time of water quality resulting from the proposed discharge in combination with previously approved discharges.

Based on the above considerations, the Department staff generally makes a case-by-case determination as to whether a new or increased discharge will result in a lowering of existing water quality. Where the new or increased discharge will consume greater than 20% of the remaining assimilative capacity for dissolved oxygen or other water quality parameter, the resulting lowering of water quality will generally be considered by Department to be lowered based upon the Department staff's historical practice and best experience and judgment.

Where the Department determines that a new or increased discharge will result in a lowering of existing water quality, the Department may then examine whether the lowering of water quality is necessary to achieve important economic or social benefits to the State. *See* 38 M.R.S. §§414-A(1)(C), 464(4)(F)(5). In making this determination pursuant to the statutory standard, the Department staff generally considers the following on a case-by-case basis consistent with its historical practice and best experience and judgment as reflected in its non-binding Antidegradation Waste Discharge Program Guidance dated June 13, 2001 developed in consultation with the USEPA:

- Whether the lowering of water quality is necessary to accommodate new or increased commercial activity or industrial production while providing that: (1) the discharge consistently complies with applicable effluent limitations requiring application of best practicable treatment or new source performance standards; and (2) any existing treatment facility is appropriate and is optimally maintained.

## 5. EFFLUENT LIMITATIONS & MONITORING REQUIREMENTS (cont'd)

- The economic and social benefits that would result from the lowering of water quality. These benefits may include, but are not limited to, increases in employment, increases in local or regional income or purchasing power, increases in the community tax base, correction of an environmental or public health problem or nuisance situation (e.g., removal of overboard discharges or failing or substandard septic systems) and improved community stability. In the case of a lowering of water quality due to community growth, benefits may include an assessment of the economic and social consequences that would result if the new or increased discharge and the resulting lowering of water quality were not approved.
- The technical availability, economic feasibility, and environmental effectiveness of alternatives that could reduce or eliminate the lowering of water quality. Alternatives may include, but are not limited to, alternative discharge locations, non-discharging alternatives, alternative methods of production, improved process controls, waste water minimization technologies, improved waste water treatment facility operation and maintenance, alternative waste water treatment methodologies, and advanced treatment beyond applicable technology requirements.

Between June and September of 2019, the Department staff conducted four ambient water quality monitoring events at six sites in Belfast Bay and Penobscot Bay to determine ambient concentrations of TN in addition to many other parameters. See **Attachment F** of this Fact Sheet. To establish “existing water quality” for the purposes of evaluating the impact of nitrogen being discharged from the Nordic facility, the Department staff considered averaged data from sampling sites BB02 and PB03 to be most representative of existing water quality conditions at the outfall location. The Department staff used an arithmetic mean of the surface TN values obtained in 2019 and calculated and utilized a background concentration of 0.25 mg/L as representative of Belfast Bay. Based on the Department’s review and analyses, the Board finds that the TN discharge threshold of 21 mg/L will not consume more than 20% of the remaining assimilative capacity and thus will not lower the existing water quality of Belfast Bay. This finding is based on the following calculations:

## 5. EFFLUENT LIMITATIONS & MONITORING REQUIREMENTS (cont'd)

### Analysis of Dissolved Oxygen as the Environmental Response Indicator

#### Given:

Critical water quality threshold - 0.45 mg/L

Background concentration – 0.25 mg/l

Nordic's proposed discharge concentration of total nitrogen – 23 mg/L

Far field factor: 532:1 (calculated by Nordic and accepted by the Department as described in Section 5(b) of this Fact Sheet)

#### Finding: Proposed effluent limitation

$0.45 \text{ mg/L} - 0.25 \text{ mg/L} = 0.20 \text{ mg/l}$  (remaining assimilative capacity)

$(0.20 \text{ mg/L}) (0.2) = 0.040 \text{ mg/L}$  (20% of the remaining assimilative capacity)

$(532)(0.040 \text{ mg/L}) = 21 \text{ mg/L}$

$(7.7 \text{ MGD})(8.34 \text{ lbs/gal})(21 \text{ mg/L}) = 1,348 \text{ lbs/day}$ . The Board finds that with the imposition of this limit, the discharge will not lower the water quality of Belfast Bay. *See* 38 M.R.S. § 464(4)(F)(5).

Based on the Department staff's review and analysis and the record information as described in this Fact Sheet, the Board finds that Nordic's proposed discharge concentration of 23 mg/L would not meet the default antidegradation licensing criteria threshold of 21 mg/L at full flow. This is because, in the Department staff's view based on its review and analysis, the proposed discharge value of 23 mg/L would consume 22% of the remaining assimilative capacity of the receiving water. According to the State's antidegradation policy, and the staff's historical practice and best professional experience and judgment, this would be considered a lowering of water quality and the applicant would only be able to meet the standard if it established and the Department made the findings required by 38 M.R.S. § 464(4)(F)(5). This permit therefore limits Nordic's discharge to the default antidegradation licensing criteria threshold on 21 mg/L as explained below.

### Analysis of Eelgrass as the Environmental Response Indicator

#### Given:

Critical water quality threshold - 0.32 mg/L

Background concentration – 0.25 mg/l

Nordic's proposed discharge concentration – 23 mg/L

Dilution factor: 1,500:1 (currently mapped bed along the southern shore of Northport as mapped by the Department (see Figure 5 in Attachment F of this Fact Sheet,

## 5. EFFLUENT LIMITATIONS & MONITORING REQUIREMENTS (cont'd)

Find: Proposed effluent limitation

$0.32 \text{ mg/L} - 0.25 \text{ mg/L} = 0.07 \text{ mg/l}$  (remaining assimilative capacity)

$(0.07 \text{ mg/L}) (0.2) = 0.014 \text{ mg/L}$  (20% of the remaining assimilative capacity)

$(1,500)(0.014 \text{ mg/L}) = 21 \text{ mg/L}$

$(7.7 \text{ MGD})(8.34 \text{ lbs/gal})(21 \text{ mg/L}) = 1,348 \text{ lbs/day}$ . The Board finds that with the imposition of this limit, the discharge will not lower the water quality of Belfast Bay. *See* 38 M.R.S. § 464(4)(F)(5).

Based on the Department staff's review and analysis and the record information as described in this Fact Sheet, the Board finds that Nordic's proposed discharge concentration of 23 mg/L would not meet the default antidegradation licensing criteria threshold of 21 mg/L at full flow. The proposed discharge value of 23 mg/L would consume 22% of the remaining assimilative capacity of the receiving water. Based on the State's antidegradation policy, and the staff's historical practice and best professional experience and judgment, this would be considered a lowering of water quality. At 23 mg/L, Nordic would only be able to meet the standard if it established and the Department made the findings required by 38 M.R.S. §464(4)(F)(5). This permit therefore limits Nordic's discharge to the default antidegradation licensing criteria threshold of 21 mg/L at full permit flow.

Intervenor Upstream watch commented that the discharge of 23 mg/L of total nitrogen to Belfast Bay as proposed by Nordic may lead to eutrophication (nutrient enrichment that may lead to excessive algal or bacterial growth). The dilution and nutrient removal of those nutrients from the discharge without hydrodynamic and meteorological data and accurate predictions of possible plume paths cannot be made.

The Board finds that absent supported findings contemplated by 38 M.R.S. §464(4)(F)(5), the most stringent discharge mass limitation that would protect both dissolved oxygen and eelgrass as the environmental response indicators would be 1,348 lbs/day as a monthly average based on the dissolved oxygen and the eelgrass analysis at a full flow of 7.7 MGD. Nordic will therefore be limited to 21 mg/L and 1,348 lbs./day as a monthly average for TN.

See Section 10 of this Fact Sheet for further discussion of the State's antidegradation policy.

## 5. EFFLUENT LIMITATIONS & MONITORING REQUIREMENTS (cont'd)

Special Condition F, *Dye Study*, of this permit requires the permittee to conduct a dye study once operations have commenced and a steady state flow of 7.7 MGD has been achieved. The information derived from this dye study will assist the Department in verifying the hydrodynamics of the receiving water and dilution factors associated with the discharge. See Section 7 of this Fact Sheet for more information on the dye study requirement.

- e. Temperature - *Regulations Relating to Temperature*, 06-096 C.M.R. ch. 582, states in relevant part:

*SUMMARY: These rules provide safeguards for fresh and salt water fauna in lakes and rivers of the state, by establishing instream limits on temperature resulting from thermal discharges.*

and

*5. Tidal Water Thermal Discharges – No discharge of pollutants shall cause the monthly mean of the daily maximum ambient temperatures in any tidal body of water, as measured outside the mixing zone, to be raised more than 4 degrees Fahrenheit nor more than 1.5 degrees Fahrenheit from June 1 to September 1. In no event shall any discharge cause the temperature of any tidal waters to exceed 85 degrees Fahrenheit at any point outside a mixing zone established by the Board.*

### Analysis of Temperature

Department staff reviewed and analyzed Nordic's proposed discharge from the standpoint of applicable temperature criteria and note the following:

The factors of a worst-case scenario for the applicant's discharge at the full flow of 7.7 MGD would be as follows:

- Using the highest discharge temperature 18°C (64.4°F). (The temperature of 18°C is the highest discharge temperature identified by the applicant in its application.)
- Using the mean of the daily maximum ambient temperature – non summer 1.3°C (34.3°F), in the month of March. (Ambient temperatures are coldest in the month of March.)
- Using the mean daily maximum ambient temperature - summer 10°C (50.0°F) in the month of June. (Ambient temperatures are warmest in the month of June.)

## 5. EFFLUENT LIMITATIONS & MONITORING REQUIREMENTS (cont'd)

Intervenors Mabee-Grace-Maine Lobsterman's Union (MLU) questioned why the Department staff utilized ambient surface water temperatures to assess the impact of discharge from the Nordic facility rather than bottom temperatures taken by the NOAA eMOLT study including data collected by Nordic's own lobster expert when that eMOLT was collected from an area in close proximity to the point of discharge.

The Board finds that Department staff appropriately utilized surface water ambient temperatures in its analysis because the discharge will be buoyant and rise to surface quickly rather than settle on the bottom of the receiving water. Any impacts from the discharge temperature will therefore be expressed on the surface of the receiving water not the bottom. Calculation to assess the impacts of the discharge temperature on the near-field and far-field are as follows:

### Near-field

#### Given:

Acute near-field dilution factor 10:1 to be conservative  $\Rightarrow$  9 parts ambient, 1 part effluent. An acute near-field dilution factor is most appropriate for this analysis as temperature impacts to the environment are greatest shortly after being discharged to the environment.

Effluent flow = 7.7 MGD (from the application)

Receiving water volume = 69.3 MG (calculated from the acute near-field dilution factor of 10:1)

### Non-Summer (September 2 – May 31)

Ambient 34.3° F (1.3 °C)

Daily max effluent temperature of 64.4 °F (18° C)

#### Find the change in temperature ( $\Delta T$ ):

$$\frac{(64.4^{\circ}\text{F})(7.7 \text{ MGD}) + (34.3^{\circ}\text{F})(69.3 \text{ MGD})}{77 \text{ MGD}} = 37.3^{\circ}\text{F}$$

$37.3^{\circ}\text{F} - 34.3^{\circ}\text{F} = 3.0^{\circ}\text{F} < 4^{\circ}\text{F}$  Based on Department's staff review and analysis and the record information as described in this Fact Sheet, the Board finds that this worst-case scenario of a change of 3.0°F for non-summer would be below, and thus meet the non-summer licensing criteria in 06-096 C.M.R ch, 582.

### Summer (June 1 – September 1)

Ambient 50.0 °F (10° C)

Daily max effluent temperature of 64.4 °F (18° C)

## 5. EFFLUENT LIMITATIONS & MONITORING REQUIREMENTS (cont'd)

Find the change in temperature ( $\Delta T$ ):

$$\frac{(64.4^{\circ}\text{F})(7.7 \text{ MGD}) + (50.0^{\circ}\text{F})(69.3 \text{ MGD})}{77 \text{ MGD}} = 51.4^{\circ}\text{F}$$

$51.4^{\circ}\text{F} - 50.0^{\circ}\text{F} = 1.4^{\circ}\text{F} < 1.5^{\circ}\text{F}$  Based on Department's staff review and analysis and the record information as described in this Fact Sheet, the Board finds that this worst-case scenario of a change of  $1.4^{\circ}\text{F}$  for summer would be below, and thus meet the summer licensing criteria in 06-096 C.M.R ch, 582.

Far field

Given:

Far-field dilution factor 532:1 to be conservative  $\Rightarrow$  531 parts ambient, 1 part effluent.

Effluent flow = 7.7 MGD (from the application)

Receiving water volume= 4,089 MG (calculated from the far-field dilution factor of 532:1)

Non-Summer (September 2 – May 31)

Ambient  $34.3^{\circ}\text{F}$  ( $1.3^{\circ}\text{C}$ )

Daily max effluent temperature of  $64.4^{\circ}\text{F}$  ( $18^{\circ}\text{C}$ )

Find the change in temperature ( $\Delta T$ ):

$$\frac{(64.4^{\circ}\text{F})(7.7 \text{ MGD}) + (34.3^{\circ}\text{F})(4,089 \text{ MGD})}{4,097 \text{ MGD}} = 34.4^{\circ}\text{F}$$

$34.4^{\circ}\text{F} - 34.3^{\circ}\text{F} = 0.1^{\circ}\text{F} < 4^{\circ}\text{F}$  Based on Department's staff review and analysis to date, this worst-case scenario for non-summer would be below, and thus meet the non-summer licensing criteria if permitted.

Summer (June 1 – September 1)

Ambient  $50.0^{\circ}\text{F}$  ( $10^{\circ}\text{C}$ )

Daily max effluent temperature of  $64.4^{\circ}\text{F}$  ( $18^{\circ}\text{C}$ )

Find the change in temperature ( $\Delta T$ ):

$$\frac{(64.4^{\circ}\text{F})(7.7 \text{ MGD}) + (50.0^{\circ}\text{F})(4,089 \text{ MGD})}{4,097 \text{ MGD}} = 50.0^{\circ}\text{F}$$



$50.0^{\circ}\text{F} - 50.0^{\circ}\text{F} = 0.0^{\circ}\text{F} < 1.5^{\circ}\text{F}$  Based on Department's staff review and analysis to date, this worst-case scenario for summer would be below, and thus meet the summer licensing criteria if permitted.

Therefore, based on evidence in the record of ambient surface temperatures and the Department's analysis above, the Board finds the thermal discharge from the Nordic facility will meet both the summer and non-summer licensing criteria in 06-096 C.M.R. ch. 582 in the near-field and far-field.

- e. Total Phosphorus – In the marine environment, nitrogen is considered the controlling nutrient that may cause or contribute to water quality issues such as algal blooms. However, total phosphorus may be a minor contributing factor as well. This permit is establishing a monitoring requirement for total phosphorus to determine the nutrient loading from the discharge to the Belfast Bay.
- f. Fish on Hand - This permitting action is establishing a reporting requirement for monthly average and daily maximum mass of fish on hand. This parameter is intended to enable both the Department and the permittee to evaluate management practices at the facility and trends in effluent quality and receiving water impacts as it relates to fish being held on site at any given time. A minimum monitoring frequency of once per month is based on the Department's BPJ of the monitoring frequency necessary to accurately characterize facility effluent conditions.
- g. Toxics - Department rule *Surface Water Toxics Control Program*, 06-096 C.M.R. ch. 530 requires the regulation of toxic substances not to exceed levels set forth in *Surface Water Quality Criteria for Toxic Pollutants*, 06-096 C.M.R. ch. 584. Chapter 530 §(2)(D)(5) states:

*“The Department may waive or reduce testing or replace testing with requirements adequate to characterize the toxicity of identified pollutants when a discharger provides information adequate to:*

- a. *Identify all toxic pollutants present or demonstrate that no toxic pollutants are used in its processes in toxic amounts;*
- b. *Demonstrate that chemicals used in or formed by the discharger's industrial processes are not known or suspected to result in the formation of toxic pollutants in toxic amounts; and*

## 5. EFFLUENT LIMITATIONS & MONITORING REQUIREMENTS (cont'd)

c. *Demonstrate the discharger does not process or treat waters known or suspected to contain toxic pollutants.*"

Nordic's application provided a list of cleaners and therapeutants that may be used at the facility. Based on the information in this Fact Sheet, the Department has determined that the only pollutant of concern that approaches the threshold by which it has a potential to cause or contribute to a violation of the acute ambient water quality criteria is ammonia.

The toxicity of ammonia is pH and temperature dependent. Chapter 584 of the Department's rules establishes ambient water quality criteria (AWQC) for total ammonia as 7.3 mg/L (acute) and 1.1 mg/L (chronic) at a pH of 8.0 standard units (su), a temperature of 20°C (68°F) and a salinity of 30 parts per thousand (ppt). The rule does not establish AQWC for un-ionized ammonia. Allowable end of pipe concentration and mass values for total ammonia can be calculated as follows:

### Chronic

Chronic AWQC = 1.1 mg/L (based on a pH of 8.0 su, 20°C, salinity of 30 ppt)

Chronic dilution factor = 15:1

Assume 10% of the AWQC for background pursuant to 06-096 CMR 523

End of pipe (EOP) concentration = [Dilution factor x 0.9 x AWQC] + [0.1 x AWQC]

EOP concentration = [15 x 0.9 x 1.1 mg/L] + [0.1 x 1.1 mg/L] = 15 mg/L

EOP Mass: (15 mg/L)(8.34)(7.7 MGD) = 963 lbs/day

**Discharge of 0.003 mg/L < Allowable discharge of 15 mg/L**

**Discharge of 0.15 lbs/day < Allowable discharge of 963 lbs/day**

### Acute

Acute AWQC = 7.3 mg/L (based on a pH of 8.0 su, 20°C, salinity of 30 ppt)

Acute dilution factor = 10:1

Assume 10% of the AWQC for background pursuant to 06-096 CMR 523

End of pipe (EOP) concentration = [Dilution factor x 0.9 x AWQC] + [0.1 x AWQC]

EOP concentration = [10 x 0.9 x 7.3 mg/L] + [0.1 x 7.3 mg/L] = 66 mg/L

EOP Mass: (66 mg/L)(8.34)(7.7 MGD) = 4,238 lbs/day

**Discharge of 0.003 mg/L < Allowable discharge of 66 mg/L**

**Discharge of 0.15 lbs/day < Allowable discharge of 4,238 lbs/day**

The calculations above indicate the discharge does not have a reasonable potential to exceed AWQC for total ammonia. The draft permit contains a seasonal (May-October) 1/week monitoring requirement for total ammonia to track discharge levels during the time of the year when it is most toxic in the environment. Should a future statistical evaluation conducted in accordance with the methodology in Chapter 530 of the Department's rules indicate the discharge is exceeding or has a reasonable potential to exceed applicable AWQC, the Department will reopen the permit pursuant to Special Condition O to establish limitations for total ammonia to meet applicable AWQC.

- h. pH – This permitting action is establishing a pH range limit of 6.0 – 9.0 standard units (su), which is considered by the Department as a BPT for fish hatcheries and rearing facilities and consistent with the pH limit established in discharge permits for those facilities.

## 6. PERMIT DECISION SUMMARY

Based on evidence in the record and the Department's analysis of the parameters in Section 5 of this Fact Sheet, this permit establishes the following limitations and monitoring requirements:

- a. Technology-based numeric limitations for flow, biochemical oxygen demand (BOD), total suspended solids (TSS) and pH;
- b. A requirement to seasonally (May – October) monitor the effluent for total phosphorus, total ammonia, total kjeldahl nitrogen, nitrate + nitrite nitrogen;
- c. A monthly average water quality-based mass limitation for total nitrogen;
- d. A requirement for the permittee to conduct a dye study to more accurately determine the mixing characteristics of the treated effluent discharge from the facility with the receiving water;
- e. A requirement to conduct seasonal (May – October) ambient water quality monitoring at five (5) stations in Belfast Bay and deploy a minimum of two Acoustic Doppler Current Profilers (ADCPs) to gather more information on the currents and the behavior of tidal exchanges in the near field and far-field;
- f. A requirement for the facility to develop and maintain an Operations & Maintenance (O&M) Plan for the production facility and the wastewater treatment facility;
- g. A requirement to limit the use of antibiotics, fungicides, bactericides, parasiticides and other chemical compounds;

## 6. PERMIT DECISION SUMMARY

- h. A requirement for the facility to develop and maintain a Containment Management System (CMS) to prevent escape of fish from the facility;
- i. Best practicable treatment (BPT) and General Reporting requirements consistent with National Effluent Guidelines (NEG) found at 40 Code of Federal Regulations (CFR), Part 451 – *Concentrated Aquatic Animal Production Point Source Category*; and
- j. A requirement for the permittee to meet with the Department’s permitting and compliance inspection staff 90 days prior to commencement of operations, to review applicability of the permit limitations, monitoring requirements and reporting requirements.

## 7. DYE STUDY

The near-field and far-field dilution factors used in this permit decision were based on modelling efforts by the Nordic’s consultant and further review and an analysis by Department staff. Testimony by Dr. Neil Pettigrew representing Upstream Watch, and Mr. Nathan Dill of Ransom Consulting Inc. representing Nordic supported the collection of additional data to more accurately determine the mixing characteristics of the discharge with the receiving water in both the near-field and far-field upon commencement of operations of the facility. Special Condition F, *Dye Study*, of this permit therefore requires the permittee to conduct a dye study once operations have commenced and a steady state flow of 7.7 MGD has been achieved. The information derived from this dye study will assist the Department in further assessing the hydraulics and dilution factors associated with the discharge. Pursuant to Special Condition O, *Reopening The Permit For Modification*, should the results of the dye study suggest dilution factors significantly different than what was modelled, the permit may be reopened, after notice to the permittee and the service list, to incorporate revised dilution factors and revise any water quality based limitations calculated based on the revised dilution factors.

## 8. AMBIENT WATER QUALITY MONITORING

During the February 11-14, 2020 public hearing on the pending MEPDES permit/WDL, intervenors and members of the general public testified regarding their concerns about the discharge of treated waste water from the facility degrading the water quality in Belfast and Penobscot Bay. In the summers of 2018 and 2019, the Department and Nordic collected separate ambient water quality data sets in Belfast Bay at different sampling stations. In the summer of 2019, the Department established five stations for long-term ambient water quality monitoring that it considers to be representative of determining whether this discharge or other discharges are causing or contributing to the degradation of water quality over time. Special Condition G, *Ambient Water Quality Monitoring*, of the permit therefore requires the permittee to prepare an ambient water quality monitoring plan for annual seasonal (May – October)

## 8. AMBIENT WATER QUALITY MONITORING

monitoring of the five aforementioned sampling stations. At a minimum, parameters to be monitored via a sonde are temperature, salinity, pH, dissolved oxygen, chlorophyll *a*, and turbidity and parameters to be monitored via grab samples are total phosphorus, total kjeldahl nitrogen, nitrate + nitrite nitrogen. The plan must be reviewed and approved by the Department prior to implementation. In addition, Special Condition G of the permit requires the permittee to submit a monitoring plan to the Department for review and approval, to utilize a minimum of two (2) Acoustic Doppler Current Profilers (ADCPs) to gather more information on the currents and the behavior of tidal exchanges in the near-field and far-field. Ambient water quality monitoring and deployment of the ADCPs are scheduled to begin on May 1, 2021.

On or before December 31<sup>st</sup> of each year, the permittee must submit a report to the Department summarizing the data collected and report any trends or anomalies with the data. The Department will periodically review the data and make determinations as to the quality of the ambient conditions. If degradation of the water quality is determined to be violating or have a reasonable potential to violate water quality standards, the Department will conduct additional analysis or monitoring to determine the cause(s) of the degradation. If it is determined the permittee's discharge is causing or contributing to a violation of water quality standards, the permit will be re-opened pursuant to Special Condition O, *Reopening The Permit For Modification*, to incorporate appropriate water quality based limitations to address the degradation.

## 9. PATHOGENS/ANTIBIOTICS

Intervenor Upstream Watch questioned whether Nordic's proposed waste water treatment facility will prevent the discharge of harmful pathogens to Belfast Bay.

The fungicides, bactericides, parasiticides, antibiotics and therapeutants identified in Nordic's application have been reviewed by the Maine Department of Inland Fisheries and Wildlife (IFW) fish pathologist, the State of Maine veterinarian and DMR staff familiar with aquaculture. In memorandum dated February 5, 2020, the DMR stated in relevant part:

Nordic Aquafarms, with their plans of using a UV dose of 300 mJ/cm<sup>2</sup> and micron filtration down to 0.4 microns, has proposed a level of effluent treatment that far exceeds regulatory expectations for amplification prevention. Although equipment suited for mitigating the effects of amplification would have been satisfactory, Nordic Aquafarms has opted to use equipment that is much more compatible with that utilized for quarantine systems. Their proposed effluent UV dose is 10 times and their microfiltration is 200 times the minimum level expected for amplification prevention. The level of microfiltration by itself, and without use of UV, is suitable biocontainment for most bacterial pathogens and parasites of concern. The UV dose is enough to address all salmonid pathogens of significance associated with the project. If viewed for the purposes of quarantine treatment, the proposed effluent treatment combination is adequate to address all non-exotic pathogens of regulatory concern.

## 9. PATHOGENS/ANTIBIOTICS

The Board finds that Nordic's waste water treatment facility, if properly operated and maintained, is designed to prevent the discharge of pathogens that may be harmful to aquatic life in Belfast Bay.

The only compound in Nordic's application identified as being of concern is Praziquantel (trematodes) which is not FDA approved. The use of this compound is therefore not being permitted at this facility. All antibiotics must be administered in conformance with label instructions.

## 10. ANTI-DEGRADATION - IMPACT ON RECEIVING WATER QUALITY

Maine's anti-degradation policy is included in 38 M.R.S., § 464 (4)(F) and addressed in the *Conclusions* section of this permit. Pursuant to the policy, where a new or increased discharge is proposed, the Department shall determine whether the discharge will result in a lowering of existing water quality.

In determining as to whether a new or increased discharge will result in a lowering of existing water quality, the Board considers the following:

- a. The predicted change in ambient water quality, concentrations of chemical pollutants, or mass loading of pollutants under critical water quality conditions.
- b. The predicted consumption of the remaining assimilative capacity of the receiving water. The remaining assimilative capacity is the increment of existing water quality above the minimum standards of the assigned classification under critical water quality conditions.
- c. The predicted change in the ability of the receiving water to support aquatic life and to meet applicable aquatic life and habitat criteria.
- d. The possible additive or synergistic effects of the discharge in combination with other existing discharges.
- e. The cumulative lowering over time of water quality resulting from the proposed discharge in combination with previously approved discharges.

Based on the above considerations, the Department makes case-by-case determinations as to whether a new or increased discharge will result in a significant lowering of existing water quality. However, in any case where the new or increased discharge will consume greater than 20% of the remaining assimilative capacity for dissolved oxygen or other water quality parameter, the resulting lowering of water quality will be determined to be significant.

Intervenor Upstream Watch has suggested the discharge from the Nordic facility will cause a degradation of water quality in Belfast Bay.

## 10. ANTI-DEGRADATION - IMPACT ON RECEIVING WATER QUALITY

Based on ambient water quality monitoring of dissolved oxygen conducted by the Department in 2019, the Board finds that the receiving water is attaining the standards of its assigned classification of >85% saturation with the exception of naturally occurring values <85% saturation during times of stratification during the warmer months. This finding is based on the Department's water quality modelling engineer and marine biologist assessment of the discharge as discussed in Section 5(c) of this Fact Sheet. The impact to the naturally occurring area of dissolved oxygen saturation levels of less than 85% is not measurable given the buoyance of the discharge.

Surface water ambient chlorophyll *a* levels averaging <4 ug/L measured in 2019 are less than the threshold of 5 ug/L, which the Department considers to be low. The Department has also assessed the impact of the discharge of BOD at the proposed permit limitations from the Nordic facility and determined the impact to ambient dissolved oxygen levels is ten (10) times lower than the accuracy ( $\pm 0.1$  mg/L) for instruments used in ambient water quality monitoring of dissolved oxygen. The impact to ambient nitrogen at the proposed permit limitation is 50% lower than the certified laboratory minimum level of detection of 0.1 mg/L. BOD impact on water quality is well below the threshold of 20% of the remaining assimilative capacity and total nitrogen is at the 20% of the remaining assimilative capacity cited in the Department's Antidegradation Waste Discharge License Program Guidance dated June 13, 2001, developed in consultation with the USEPA.

Based on the analysis of the evidence described above, the Board finds that the discharge as approved by this permit will not result in a significant lowering of water quality. Further, the Board finds the existing and designated water uses will be maintained and protected and the discharge as permitted will not cause or contribute to the failure of the Belfast Bay to meet standards for Class SB classification. Therefore, the Board finds that as permitted, the discharge will meet the antidegradation requirements set forth in 38 M.R.S., § 464 (4)(F).

## 11. PUBLIC COMMENTS

Public notice of this application was made in the *Bangor Daily* newspaper on or about September 21, 2018. Between February 11 and February 14, 2020, the Board held an adjudicatory hearing in Belfast on Nordic's application. Except for several specific and limited matters for which it was held open, the record closed for public comment on the application on February 18, 2020. The Department receives public comments on an application until the date a final agency action is taken on the application. On August 13, 2020, the Board made the Department staff's draft recommended decision on MEPDES permit #ME0002771/Maine Waste Discharge License #W009200-6F-A-N available for a formal 30-day public comment period. Those persons receiving copies of draft permits must have at least 30 days in which to submit comments on the draft or to request a public hearing, pursuant to *Application Processing Procedures for Waste Discharge Licenses*, 06-096 C.M.R. ch. 522 (effective January 12, 2001). Substantive comments received and responses to those comments can be found in Section 13 of this Fact Sheet.

## 12. DEPARTMENT CONTACTS

Additional information concerning this permitting action may be obtained from, and written comments sent to:

Gregg Wood  
Division of Water Quality Management  
Bureau of Water Quality  
Department of Environmental Protection  
17 State House Station  
Augusta, Maine 04333-0017 Telephone: (207) 287-7693  
e-mail: [gregg.wood@maine.gov](mailto:gregg.wood@maine.gov)

## 13. RESPONSE TO COMMENTS

During the period August 13, 2020 – September 14, 2020, the MDEP made the proposed draft MEPDES permit/WDL available for a formal 30-day public comment period, consistent with the MEPDES rules. On September 24, 2020, the Board of Environmental Protection via its Twenty-First Procedural Order, granted the following entities an extension of the comment period until October 5, 2020 to amend the relevant portion of their previous submittals, or file an additional comment, to correct or augment their comments regarding nutrient removal percentages: Nordic; Upstream Watch; Northport Village Corporation; Jeffrey R. Magbee, Judith B. Grace, and Lobstering Representatives (MGL) and Friends of the Harriet L. Hartley Conservation Area 1; and Kristina Debye. The MDEP received comments from the following entities:

Mr. Stephen Rothman  
Ms. Kristina Debye  
Northport Village Corporation (NVC)  
Upstream Watch (UW)  
Jeffrey Mabee & Judith Grace, Maine Lobstering Representatives, The Friends of the Harriet L. Hartley Conservation Area (M&G)  
Holly Faubel (HF)  
Nordic Aquafarms Inc. (Nordic)

Similar comments have been combined by subject matter where possible. Responses to substantive comments are as follows.

### **Temperature**

***Comment #1 (HF)*** - The draft order's discussions and conclusion regarding temperature, near field discharge, and buoyancy is incomplete and flawed because the Department's calculation does not account for the far field impact on the near field measurements. The Department must consider the impact of the far field waters in its calculation of the near field temperature as the near field is not isolated from the far field. The Department's calculations must consider that there is an accumulated temperature differential occurring in both fields as the effluent stream is not a discrete flow but a steady state 24/7/365.



**Response #1:** The far-field dilution factor is 53 times greater than the acute (near-field) dilution used in the initial Fact Sheet calculations which indicates the temperature licensing criteria for temperature has been met. The calculations using a far-field dilution will indicate an even lower impact from temperature. Utilizing the same formula on pages 28 and 29 of the initial draft Fact Sheet, which shows the impact of the discharge temperature in the near field, the impact of the discharge temperature in the far-field may be calculated as follows:

Given:

Far-field dilution factor 532:1 to be conservative  $\Rightarrow$  531 parts ambient, 1 part effluent.

Effluent flow = 7.7 MGD (from the application)

Receiving water volume= 4,089 MG (calculated from the far-field dilution factor of 532:1)

Non-Summer (September 2 – May 31)

Ambient 34.3° F (1.3 °C)

Daily max effluent temperature of 64.4 °F (18° C)

Find the change in temperature ( $\Delta T$ ):

$$\frac{(64.4^{\circ}\text{F})(7.7 \text{ MGD}) + (34.3^{\circ}\text{F})(4,089 \text{ MGD})}{4,097 \text{ MGD}} = 34.4^{\circ}\text{F}$$

$34.4^{\circ}\text{F} - 34.3^{\circ}\text{F} = 0.1^{\circ}\text{F} < 4^{\circ}\text{F}$  Based on Department's staff review and analysis to date, this worst-case scenario for non-summer would be below, and thus meet the non-summer licensing criteria if permitted.

Summer (June 1 – September 1)

Ambient 50.0 °F (10° C)

Daily max effluent temperature of 64.4 °F (18° C)

Find the change in temperature ( $\Delta T$ ):

$$\frac{(64.4^{\circ}\text{F})(7.7 \text{ MGD}) + (50.0^{\circ}\text{F})(4,089 \text{ MGD})}{4,097 \text{ MGD}} = 50.0^{\circ}\text{F}$$

$50.0^{\circ}\text{F} - 50.0^{\circ}\text{F} = 0.0^{\circ}\text{F} < 1.5^{\circ}\text{F}$  Based on Department's staff review and analysis to date, this worst-case scenario for summer would be below, and thus meet the summer licensing criteria if permitted.

The calculations above have been incorporated into the final Fact Sheet. Whether the Department examines the near-field or far-field, the calculations show that the discharge temperature would meet the summer and non-summer licensing criteria. Therefore, the Board Order remains unchanged.

## **pH**

**Comment #2 (HF)** - The initial draft order specifies pH levels ranging between 6.0 and 9.0. A discharge level of 6.0 will significantly contribute to acidification and degradation of the Bay and adjacent waters. This is a serious degradation of the nursery beds for all fin-fish and overwintering flounder habitat. It fails to preserve and protect the water quality and all fauna and flora that inhabit the Bay.

**Response #2** – A pH range of 6.0 – 9.0 standard units (su) for the discharge from Nordic’s facility meets the requirements of Maine law and is consistent with established practices of the Department. Title 38 M.R.S. §464(4)(A)(5) prohibits the “[d]ischarge of pollutants to any water of the State that violates sections 465, 465-A and 465-B, except as provided in section 451 ... or causes the "pH" of estuarine and marine waters to fall outside of the 7.0 to 8.5 range.”

Page 30 of the initial draft Fact Sheet states:

- h. pH – This permitting action is establishing a pH range limit of 6.0 – 9.0 standard units (su), which is considered by the Department as a BPT for fish hatcheries and rearing facilities and consistent with the pH limit established in discharge permits for those facilities.

Title 38 M.R.S. §451 provides for a reasonable mixing zone that allows for dilution and diffusion of pollutants, stating in relevant part:

The purpose of a mixing zone is to allow a reasonable opportunity for dilution, diffusion or mixture of pollutants with the receiving waters before the receiving waters below or surrounding a discharge will be tested for classification violations. In determining the extent of any mixing zone to be established under this section, the department may require from the applicant testimony concerning the nature and rate of the discharge; the nature and rate of existing discharges to the waterway; the size of the waterway and the rate of flow therein; any relevant seasonal, climatic, tidal and natural variations in such size, flow, nature and rate; the uses of the waterways in the vicinity of the discharge, and such other and further evidence as in the department's judgment will enable it to establish a reasonable mixing zone for such discharge.

Using the most stringent dilution factor of 10:1 (acute) a discharge of 6.0 or 9.0 su will not cause the pH of the receiving water outside of the mixing zone to fall outside of the permissible range of 7.0 – 8.5 su specified in section 464(4)(A)(5). Therefore, the Board Order remains unchanged.

**Ammonia:**

**Comment #3 (HF)** – Ammonia is toxic to finfish. The absence of targets for or limits on unionized ammonia threatens the Bay’s ability to support endangered and important lifeforms.

**Response #3:** According the application submitted to the Department on October 19, 2018, the permittee anticipates a discharge concentration of 0.003 mg/L and 0.07 kg/day or 0.15 lbs/day. Department staff evaluated the proposed discharge concentration early on in the review of the application materials and made the determination that the proposed discharge would not exceed or have a reasonable potential to exceed applicable ambient water quality criteria (AWQC) for ammonia by a wide margin. Given the comment submitted, Department staff has prepared the calculations below.

The toxicity of ammonia is pH and temperature dependent. Chapter 584 of the Department’s rules establishes AWQC for total ammonia as 7.3 mg/L (acute) and 1.1 mg/L (chronic) at a pH of 8.0 standard units (su), a temperature of 20°C (68°F) and a salinity of 30 parts per thousand (ppt). The rule does not establish AWQC for un-ionized ammonia. Allowable end of pipe concentration and mass values for total ammonia can be calculated as follows:

**Chronic**

Chronic AWQC = 1.1 mg/L (based on a pH of 8.0 su, 20°C, salinity of 30 ppt)  
Chronic dilution factor = 15:1  
Assume 10% of the AWQC for background pursuant to 06-096 CMR 523  
End of pipe (EOP) concentration = [Dilution factor x 0.9 x AWQC] + [0.1 x AWQC]  
EOP concentration = [15 x 0.9 x 1.1 mg/L] + [0.1 x 1.1 mg/L] = 15 mg/L  
EOP Mass: (15 mg/L)(8.34)(7.7 MGD) = 963 lbs/day

Discharge of 0.003 mg/L < Allowable discharge of 15 mg/L  
Discharge of 0.15 lbs/day < Allowable discharge of 963 lbs/day

**Acute**

Acute AWQC = 7.3 mg/L (based on a pH of 8.0 su, 20°C, salinity of 30 ppt)  
Acute dilution factor = 10:1  
Assume 10% of the AWQC for background pursuant to 06-096 CMR 523  
End of pipe (EOP) concentration = [Dilution factor x 0.9 x AWQC] + [0.1 x AWQC]  
EOP concentration = [10 x 0.9 x 7.3 mg/L] + [0.1 x 7.3 mg/L] = 66 mg/L  
EOP Mass: (66 mg/L)(8.34)(7.7 MGD) = 4,238 lbs/day

Discharge of 0.003 mg/L < Allowable discharge of 66 mg/L  
Discharge of 0.15 lbs/day < Allowable discharge of 4,238 lbs/day

The calculations above indicate the discharge does not have a reasonable potential to exceed AWQC for total ammonia. The draft permit contains a seasonal (May-October) 1/week monitoring requirement for total ammonia to track discharge levels during the time of the year when it is most toxic in the environment. Should a future statistical evaluation conducted in accordance with the methodology in Chapter 530 of the Department's rules indicate the discharge is exceeding or has a reasonable potential to exceed applicable AWQC, the Department will reopen the permit pursuant to Special Condition O, *Reopening the permit For Modifications*, to establish limitations for total ammonia to meet applicable AWQC.

The calculations above have been incorporated into the final Fact Sheet. The Board Order otherwise remains unchanged.

### **Best Practicable Treatment (BPT) Limitations/Water Quality Based Limitations (WQBL)**

**Comment #4 (UW, MGL, HF)** – With regard to technology-based (BPT) numeric limitations for flow, biochemical oxygen demand (BOD), total suspended solids (TSS), and pH, Nordic has provided insufficient information to determine what the actual removal efficiencies should be. Many of the parameters associated with the effluent are experimental in nature (unique feed, unique RAS, unique treatment, size of operation, uncertain marine water flow parameters and recirculation uncertainties, etc.) Nordic has provided insufficient information to assess and develop technology based effluent limitations. Nordic has never built or operated a facility of this size and nature.

**Response #4** - Technology based (BPT) effluent limitations in discharge permits are not established based on the removal efficiency of treatment technology proposed or installed at a particular wastewater treatment facility. Rather, BPT standards are established for a category or class of discharge sources. For example, Chapter 525, § 3 of the Department's rules establishes technology based limitations for biochemical oxygen demand (BOD) and total suspended solids (TSS) of 30 mg/L as a monthly average, 45 mg/L as a weekly average and a minimum of 85% removal for both BOD and TSS for facilities that are providing a secondary level of treatment. These technology-based limitations apply to most all municipal dischargers in the state because those dischargers are required to provide a secondary level of treatment pursuant to the Department regulations and the CWA. (Eight municipal facilities, including Northport Village Corporation's facility, have received a waiver from secondary treatment requirements. Pursuant to 40 C.F.R. § 125.58(r), BPT for these so-called 301(h) facilities is 30% removal of BOD and TSS as a monthly average.)

Another example of BPT limitations for a class or category of discharge sources is the pulp and paper industry. BPT for BOD and TSS in these permits is based on an evaluation of different treatment technologies utilized in the industry around the world. The evaluation takes into consideration the existing state of technology, the effectiveness of the available alternatives for control of the type of discharge, and the economic feasibility of such alternatives. The USEPA publishes National Effluent Guidelines (NEGs) for each category of pulp and papermaking based on the aforementioned evaluation and expresses monthly average and daily maximum BPT as “X” pounds of BOD and TSS per ton of pulp and or paper production. BPT based mass limitations are then calculated accordingly and placed in the discharge permits.

When, as here, no standards exist for a source, BPT must be determined on a case-by-case basis. *Conditions of licenses*, 38 M.R.S. § 414-A(1)(D), states in relevant part:

If no applicable standards exist for a specific activity or discharge, the department must establish limits on a case-by-case basis using best professional judgment, after consultation with the applicant and other interested parties of record. In determining best practicable treatment for each category or class, the department shall consider the existing state of technology, the effectiveness of the available alternatives for control of the type of discharge and the economic feasibility of such alternatives.

Page 17 and 18 of the initial draft Fact Sheet explains the Board’s rationale for the establishing the monthly average and daily maximum concentration limitations for BOD and TSS for Nordic’s facility. In turn, those BPT concentration limitations were utilized to calculate the monthly average and daily mass limitations for BOD and TSS as required by Chapter 523 §6(f) of the Department rules. The relevant text in the Fact Sheet is as follows:

Currently, there are no state or federally promulgated best practicable treatment (BPT) numeric standards for BOD<sub>5</sub> and TSS for land-based RAS facilities. In 2004, the USEPA promulgated standards for RAS facilities based on narrative best management practices (BMPs) controls but opted not to establish numerical BPT standards for BOD<sub>5</sub> and TSS at this time. However, the Department has historically been more stringent than the federally promulgated standards and has established numeric limitations for both parameters. The Department has issued MEPDES permits/WDL for other RAS facilities establishing monthly average and daily maximum concentration limits of 30 mg/L and 50 mg/L respectively for BOD<sub>5</sub> and TSS based on Department BPJ of BPT for RAS facilities. These limits were based on BPT recommendations included in USEPA’s 2004 proposed draft National Effluent Guidelines for TSS for re-circulated fish hatchery wastewater receiving a secondary level of treatment and the Department’s long-standing view of the relationship between TSS and BOD<sub>5</sub>. For the proposed discharge from the Nordic facility, mass limits are calculated based on the monthly average flow limit of 7.7 MGD, the applicable concentration limits of 30 mg/L and 50 mg/L (based on the Department’s historic practice and BPJ) and a conversion factor of 8.34 lbs/gal for water.

The monthly average and daily maximum BPT concentration limits of 30 mg/L and 50 mg/L respectively established in the initial draft order for BOD<sub>5</sub> and TSS are based on Department BPJ of BPT for RAS facilities, a category of discharges, consistent with *Conditions of licenses*, 38 M.R.S. § 414-A(1)(D). In addition, all relevant BMP's promulgated by EPA in *Final Effluent Limitations Guidelines and New Source Performance Standards for the Concentrated Aquatic Animal Production Point Source Category* (40 CFR Part 451) are included as requirements in the order. Therefore, the Board Order remains unchanged.

**Comment #5 (UW):** A NPDES permit should address implementing requirements under the Clean Water Act's Total Maximum Daily Load (TMDL) programs. The initial draft order does not contain such requirements. A TMDL should be a calculation of the greatest amount of a pollutant that a waterbody can receive without exceeding water quality standards. It is the sum of the allowable loads of a single pollutant from all contributing point and non-point sources. The calculation must include a margin of safety to ensure that the waterbody can be used for the purposes the state has designated. The calculation must also account for seasonal variation in water quality. Without a TMDL calculation, the Department cannot know the impact of the discharge on Penobscot Bay. Intervenors have repeatedly requested that water quality-based effluent standards be developed.

**Response #5:** TMDLs are prepared for non-attainment waterbodies. See 33 U.S.C. § 1313(d). The Board is not aware of information indicating that Belfast Bay is not attaining the standards of its assigned classification of Class SB. Water quality based effluent limits (WQBELs) are imposed on dischargers when BPT limitations are not stringent enough to meet the waterbody's classification standards or if the proposed discharge is calculated to cause or contribute to the non-attainment of a waterbody. Please note that there is one WQBEL established in the initial draft order for total nitrogen. Pages 19-26 of the Fact Sheet of the initial draft order provide a detailed analysis of the reasoning behind the establishment of this water quality-based limitation. The WQBEL is being established to protect the dissolved oxygen standard of Class SB waters in accordance with the state's antidegradation policy. Based on the Board's analysis of the information in the record, WQBELs are not required for any pollutant other than total nitrogen. Therefore, the Board Order remains unchanged.

### **Fish Feed**

**Comment #6 (UW)** - Multiple papers suggest that some fish feeds used for land-based aquaculture contain toxic chemicals. Although Nordic claims there will be no toxins in the feed it uses, Nordic has refused to reveal its fish feed selection. Additionally, the initial draft order does not specify certification standards for fish feed to ensure that the feed will not have toxins present. Therefore, only after the fact monitoring can provide assurances that toxins are not entering the waste effluent as a byproduct of the fish food. The permit must include provisions for monitoring the sludge waste and the pipe discharge waste for toxins.

**Response #6** – Special Condition L, *Fish Feed*, of the draft order states follows:

**At least 90 days prior to stocking the site with fish feed**, the permittee must submit a detailed list of ingredients in the feed. If the list contains ingredients of concern, the Department reserves the right to reopen the permit pursuant to Special Condition O, *Reopening of Permit for Modifications*, to establish additional limitations and or monitoring requirements for the ingredients of concern.

The special condition is designed to address the commenter's concern on monitoring the effluent. As for the monitoring the sludge for toxics, several composting and waste disposal and transport companies provided letters of commitment to accept the sludge wastes generated by Nordic's waste water treatment facility. These companies include Crossroads Landfill, Casella Organics, Agri-Cycle Energy, Channel Fish Company, Coast of Maine Organic Products, and Compost Maine. These entities are regulated by the Department's Bureau of Remediation and Waste Management. Therefore, the Board Order remains unchanged.

### **Dilution/Bay Circulation**

**Comment #7 (UM):** Because Nordic has failed to provide local, site specific data, the utility, reliability, and accuracy of Nordic's models has been compromised. Nordic's current models are not accompanied by data necessary to verify their accuracy and fail to account for secondary circulation, wind shear, stratification, and other anomalies associated with the Bay. Nordic's modeling is therefore unsuitable for the purpose of determining dilution factors used to set precise discharge concentrations, especially when the model predicts impacts on the cusp of or exceeding State standards. The limited data Nordic has provided for nutrients, oxygen, and stratification demonstrates potential problems with meeting water quality objectives. The Board should not grant a permit until an annual cycle of monitoring and updated circulation modeling can reasonably demonstrate that water quality objectives will be met. Because plume dynamics and existing conditions in the receiving water are critical to evaluating any project-related changes in the water column in near-field communities and other environmental consequences of the project, the size and location of the discharge plume must be defined with a rigorous, year-round study. After-the-fact modeling is too late.

**Response #7-** In the Board's view, Nordic's modeling effort to date examines a reasonably confined area in the immediate vicinity of the outfall, where influences from the discharge will be greatest and provides sufficient, credible evidence to support the findings in the Board Order. The modeling is not intended to examine the entirety of Penobscot Bay. Defining the specific behavior of the plume within the reasonably confined area in the vicinity of the outfall is a significantly simpler and more accurate effort and provides more conservative results than doing so in the larger area of the bay as a whole. The primary purpose of the effort is to ensure that water quality standards can be met. Were the model to examine influences significantly outside of the defined area that the model currently looks at, the model would show significantly less influences and would have significantly greater degree of assumed error. Additionally, Nordic's modeling effort specifically excludes a variety of factors that would result in less conservative estimates of mixing. For example, the model does not incorporate a variety of atmospheric conditions, such as wind shear, because this would suggest a greater dilution.

Although the intervenors object that after-the-fact verification of the modeling results is too late, dye studies of the type required by the initial draft order cannot be properly simulated without an operational discharge. The primary purpose of the dye study is to verify modeling assumptions.

The Board agrees with the commenters, however, that conducting additional current monitoring in the receiving water prior to the commencement of the discharge may strengthen the verification of the existing modeling results to ensure that water quality objectives will be met. Therefore, Special Condition G, *Ambient Water Quality Monitoring*, has been modified to require Nordic to submit a plan of study to the Department on or before March 1, 2021, to utilize a minimum of two (2) Acoustic Doppler Current Profilers (ADCPs) to gather more information on the currents and the behavior of tidal exchanges in the near field and far-field. Nordic must commence ambient monitoring at designated sites established by the Department beginning May 1, 2021.

Should the monitoring results of the ADCPs indicate the existing modeling results are not accurate, the Department may use Special Condition O, *Reopening The Permit For Modifications*, to modify limitations and or require additional information/data be collected to confirm that water quality standards are being met in the receiving water.

### **Dye study**

**Comment #8 (UW):** Special Condition F, *Dye Study*, of the initial draft order includes a requirement for a dye test to be performed when the facility reaches full steady state flow of 7.7 MGD. The initial draft order provides for no consequences if the dye tests show non-conformance with the permit or misrepresentation in the process of obtaining a permit or fail to verify Nordic's current modeling. As intervenors have consistently requested, the dye test should be designed and implemented before the Board grants a permit. To perform a dye test after the facility has already been constructed is too late as permanent damage to the environment, fisheries, and property values might already have occurred.

**Response #8:** In the Board's view, the predicted modeling results to date provide sufficient, credible evidence to support the findings in the Board Order. The dye study required by the initial draft order is intended to determine the accuracy of and provide additional assurance regarding the predicted model results for the near-field and far-field not the circulation patterns of the larger area of Belfast Bay or Penobscot Bay. As noted above, dye studies of the type required in the initial Board Order cannot be properly simulated without an operational discharge. The primary purpose of the dye study is to verify modeling assumptions.



Page 8 of the Fact Sheet states Special Condition F, *Dye Study*, requires Nordic to conduct a dye study once operations have commenced and a steady state flow of 7.7 MGD has been achieved. Although intervenors are concerned that an “after-the-fact” dye study is insufficient and that there would be no consequences if it did not confirm the modeling, the draft order allows the Department to address these concerns. The information derived from this dye study will assist the Department in confirming and more accurately assessing the hydrodynamics of the receiving water and dilution factors associated with the discharge. Should the monitoring results of the dye study indicate the modeling results to date are not accurate, pursuant to Special Condition O, *Reopening The Permit For Modifications*, the Department may modify limitations and require additional information/data be collected to confirm that water quality standards are being met in the receiving water. The Board Order remains unchanged.

### **Pathogens/Viruses/Disease Control**

**Comment #9(HF)** – Nordic’s application does not utilize a science base approach and does not justify its rationale for failing to do so.

**Response #9** - Applications for projects such as that proposed by Nordic are reviewed by multiple agencies and by various working groups on behalf of state and federal agencies. Regardless of what science may or may not be provided as part of an application, the review process conducted by the state is “science-based.” Reviews are based on principles in Department rule, interpretation of statute, use of guidelines referenced in rule, literature review, and the solicited opinions of seasoned aquatic animal health professionals from within and outside of the state. Although the commenter has directed this comment towards the Department, given the nature of the comments and questions, they are better addressed by the Maine Department of Marine Resources (MDMR), the agency with regulatory authority to address aquatic pathogen concerns via licensing and permitting conditions for cultivation, importation, transfer, and by the powers of the MDMR Commissioner with respect to actions that can be taken in response to reportable pathogens of regulatory concern. See MDMR Rules, Chapter 24.15(3) (giving MDMR’s Commissioner authority to include permit conditions “necessary to protect indigenous marine life or its environment including through quarantine”) and 12 M.R.S. § 6071(2 & 3) (governing permits and rules for importing living marine organisms including provisions to prevent the introduction of pathogens). As part of this licensing proceeding, the Department requested and received comments from MDMR and the Maine Inland Fisheries and Wildlife (MIFW) on February 5, 2020. The Board Order remains unchanged.

**Comment #10 (HF)** – Intervenors provided copious testimony in the area of virology and salmon aquaculture including testimony describing the viruses that may infect livestock in the tank without causing them to display symptoms. The effluent could expose the wild salmon and other finfish to a variety of lethal viruses regardless of whether the livestock have been vaccinated.

**Response #10** – The protection of state marine resources, including wild salmon and finfish, from pathogens, parasites, or pests that may be introduced through aquaculture or aquatic animal imports falls within the jurisdiction of the MDMR, it is not within the scope of Nordic’s WDL/MEPDES permit. Pursuant to MDMR rule Chapter 24 and Statute 6071, Nordic must obtain permits from MDMR for all eggs and/or fish to be stocked within the facility. The Commissioner of MDMR may grant such a permit only if the Commissioner finds to a reasonable degree of certainty that those actions will not endanger the indigenous marine life or its environment (MDMR Chapter 24.15). Furthermore, MDMR Chapter 24.21 regulations require a comprehensive record of fish health testing at the source facility to meet Maine standards as a “qualified source/hatchery” or utilization of a department approved and inspected quarantine facility with requirements for pre-import and post import testing that have been established by the Commissioner in consultation with the Maine Aquatic Animal Health Technical Committee.

Pursuant to 12 M.R.S. §6085, Nordic is further required to obtain a land-based aquaculture license from MDMR. When reviewing applications for land-based aquaculture, MDMR considers the potential risks of the proposed activities to marine resources and the environment. When assessing potential risks to resources of the state, the MDMR includes, but is not limited to, evaluation of the source of organisms to be cultivated at the facility, the proposed biosecurity plan, and the effectiveness of any proposed effluent treatment. The Board Order remains unchanged.

**Comment #11:** There is a likelihood that viruses will be discharged to which wild fish have no previous immunity. The use of the word “Quarantine” in Nordic’s application is inaccurate, incorrect and incomplete in regard to viral pathogens and the use of UV light. Quarantine is the separation and restriction of the movement of livestock exposed to contagious disease, and the livestock’s water to see if they become sick. “Isolation” is the separation of sick livestock from livestock who are not sick. The facility diagrams and textual descriptions of operations in Nordic’s application, show no quarantine tanks or isolation tanks. Quarantine facilities for viruses must be capable of supporting all livestock for a minimum period of two weeks to determine if there is disease present and how much of the stock and its cohorts sicken.

**Response #11** – As discussed in Response #10, MDMR has the authority over the import and introduction of salmonids to coastal waters of the state, including to land-based facilities that discharge to waters of the state. Although Nordic, in plans submitted to the Department as part of these proceedings, designated an area for quarantine, MDMR will ultimately establish the requirements for quarantine, inclusive of effluent treatment from quarantine, at the proposed Nordic facility. MDMR has rigorous standards for protecting state resources that are satisfied through licensing and permitting requirements for salmon egg sources, inclusive of a comprehensive record of fish health testing at the source facility and extra requirements for pre-import fish health inspection, egg disinfection, post import quarantine requirements, post import fish health testing, release from quarantine requirements, and fish health monitoring requirements during production. These MDMR licensing and permitting requirements are not within the scope of the WDL/MEPDES permit at issue in these proceedings. The Board Order remains unchanged.

Although the commenter offers practices, concepts, and definitions of quarantine, please note that MDMR defines terms related to quarantine, including “quarantine facility” in its rules. See MDMR rule Chapter 24.

**Comment #12 (HF)** - To address viruses that could contaminate wild fish, the isolation tanks would need to be fully supported for the length of the treatment cycle, a minimum of ten days without discharge. Nordic’s facility, however, is designed for partially open operation. A supporting operations plan must be available in order to judge Nordic’s ability to properly perform quarantine and isolation.

**Response #12** - See Responses #10 and #11, which address MDMR’s role in protecting marine resources from pathogens. Because there are no FDA-approved treatments for viruses in finfish aquaculture, a requirement to demonstrate the ability to operate for ten days without discharge for the purposes of treating viruses is unnecessary. Additionally, although the facility is partially open, Nordic has provided a plan for whole facility effluent treatment, which includes solids filtration to retain particles greater than 0.04 microns (40 nanometers) followed by UV at 300 mJ/cm<sup>2</sup> and exceeds MDMR’s standards for mitigating risk associated with potential amplification and release of aquatic pathogens. The Board Order remains unchanged.

**Comment #13 (HF)** - Fish skin is sensitive to extended high levels of UV exposure. It is not advisable to expose fish to high concentrations of UV for long periods as it causes injury and diminishes fish health, which makes them more susceptible to disease. If the isolation tanks are permitted to discharge effluent, higher levels of therapeutic drugs would be required. The levels of therapeutics discharged from Nordic’s facility will be much higher than past RAS fish hatchery data because of the significantly higher size and volume of fish production.

**Response #13** – The Board agrees that UV light should not be used to treat disease in fish for the reasons mentioned. In aquaculture and in Nordic’s plan for whole facility effluent treatment as described in its application, UV is not used to treat disease in which fish are swimming. Rather, it is used to disinfect process water that is filtered and returned to the rearing tanks for the purposes of preventing microbial amplification. The Board Order remains unchanged.

**Comment #14 (HF)** – A proposed 0.04 micron filter does not remove viruses which can be 0.03 microns in size. Even using a combination of a 0.04 micron filter and UV light Nordic’s partially open RAS facility will discharge effluent containing viruses into the waters of Belfast Bay.

**Response #14** - The Board finds that the proposed 0.04 micron (40 nanometer) filter will remove all bacteria, fungi, and parasites. Additionally, the finer level of filtration will also remove most viral agents of possible concern, including all listed viral agents of regulatory concern. Viruses that do pass filtration will be subject to high dose UV disinfection. The 300 mJ/cm<sup>2</sup> is sufficient to neutralize the threat of any finfish viruses of regulatory concern that make it past membrane filtration. Both the membrane filter and the UV disinfection specifications are suitable for preventing the release of pathogens of regulatory concern. The addition of the finer level solids filtration of 0.04 microns results in Nordic’s biocontainment plan having effective redundancy for preventing the release of pathogens when it is coupled with the UV disinfection unit. The entire facility, as proposed, could be considered a quarantine unit. As discussed above, Nordic’s plan for filtration and disinfection exceeds MDMR’s standards for mitigating risk associated with potential amplification and release of aquatic pathogens. The Board Order remains unchanged. For reference, the following table shows the size of different viruses abbreviated in parentheses.

<b><u>Virus</u></b>	<b><u>Size (microns)</u></b>
<u>Iridoviruses (EHNV, RSIV, LMBV, LCDV)</u>	<u>0.12 to 0.227</u>
<u>Herpesviruses(OMV, SaIHV, CCV, KHV, AngHV)</u>	<u>0.12 to 0.20</u>
<u>Rhabdoviruses (IHNV, VHSV, SVCV)</u>	<u>0.07 x 0.18</u>
<u>Orthomyxoviruses (ISAV, TiLV, influenza)</u>	<u>0.08 to 0.12</u>
<u>Reoviruses (PRV, EIBS)</u>	<u>0.07 to 0.08</u>
<u>Birnaviruses (IPNV)</u>	<u>0.065</u>
<u>Nodavirus (VNNV)</u>	<u>0.025 (endemic to Maine)</u>
<u>Hepesvirus (Cutthroat trout virus)</u>	<u>0.03 (Exotic, small enough to pass filter, but low concern and consequence)</u>

**Comment #15 (UW)** - The initial draft order contains insufficient procedures for monitoring disease. Methods, diseases, and detection limits must be provided. Nordic must comply with Maine Department of Inland Fisheries and Wildlife (IFW) and Maine Department of Marine Resources (MDMR) fish health laws, 12 M.R.S §§ 6071, 10051, 10105, 12507, and 12509, which include requirements for notification to the appropriate agency within 24-hours of pathogen detection. Nordic should also be required to notify the Department in writing within 24 hours following pathogen detection.

IFW rules do not cover testing for diseases, and many of the intervenor’s concerns are not addressed by IFW. For example, 12 M.R.S. § 10105 contains a subjective requirement for disposal of dead fish “in any manner considered appropriate by the commissioner.” Any fish death due to viruses must be managed in a pre-prescribed manner, including reporting to the public, fisheries, the Department, and Maine CDC, and handled to prevent further transmission of the viruses. Should a mass die-off due to viruses occur, Nordic must report to the Maine CDC and must cede control of the facility to state health and environmental officials until, in the opinion of the Maine CDC, the viral crisis has passed.

**Response #15** - As discussed above, MDMR, rather than IFW or the Department, has regulatory jurisdiction over the protection of marine resources and the environment from pathogens from aquaculture facilities. *See* 12 M.R.S. § 6071; MDMR Rules Chapter 24. From a regulatory standpoint, DMR is the appropriate agency to respond to an aquatic animal disease outbreak in an aquaculture setting. *See* Response #9. The Board Order remains unchanged.

**Comment #16 (UW)** – The initial draft order provides no monitoring plan for viral and bacterial contamination in the discharge, which is especially concerning given the spread of Covid-19 from animals to humans in China. Detailed sampling criteria, enforceable limits, and analytical protocols including reporting and control of the site need to be developed. Examples of concerns include:

- Infectious salmon anemia (ISA) or ISAv (v for virus) is endemic to the Atlantic.
- Infectious Pancreatic Necrosis (IPN) or IPNv is endemic to Atlantic Canada and therefore probably Maine as well.
- *Aeromonas salmonicida* is also common in the North.

**Response #16** - As discussed above, the MDMR has regulatory authority over aquatic pathogens. MDMR has established fish health rules that include detailed sampling criteria, acceptable testing methods, reporting requirements, and consequences for the detection of certain pathogens. Nordic will be required to comply with applicable MDMR statutes and rules. The pathogens mentioned by the commenter are just a few of the many pathogens regulated by the state. The Board Order remains unchanged.

**Comment #17 (UW)** - In a new modification, Nordic's MBR filters for intake and effluent will now be 40 nanometers instead of 400 nanometers (0.4 microns). This is a significant change in the treatment process. Filtering at this level presents significant new technological variables in treatment including clogging of the filter, pressures and pump changes, and the potential need for bypass. Because the filters are likely to become clogged, bypass requirements, facilities, and resultant conditions need to be studied and more thoroughly considered. Additionally, 40 nanometers will not remove viruses, which are typically less than 1 nanometer. Nordic will be unable to stop the free transmission of viruses from the outside into their system where the viruses will be concentrated and freely discharged back into the Bay.

**Response #17** – According to Nordic's application, filtration membranes will be equipped with automatic clean-in-place (CIP) systems to prevent clogging of the membranes. Additionally, viruses are not typically less than 1 nanometer. Aquatic viruses and their sizes are listed in response #14 of this section. The smallest known viral pathogens (Parvoviruses) are about 18 nanometers or 0.018 microns in size. The Board Order remains unchanged.

**Comment #18 (UW)** - The IFW rules and laws do not address specific disease monitoring or analytical procedures to assure a wide spectrum of viral or bacteriological diseases are addressed.

**Response #18** - As discussed above, the MDMR, and not MIFW or the Department, has authority over the culture of marine species, including salmonids, and Chapter 24 of MDMR Rules applies to Nordic's facility. These rules and their reference documents contain specific monitoring, analytical, and reporting procedures to assure a wide spectrum of pathogens are addressed. Chapter 24 of MDMR Rules also references standards outlined in The AFS Bluebook, the OIE (World Organization for Animal Health), and the Northeast Fish Health Committee Guidelines. The Board Order remains unchanged.

**Comment #19 (UW)** – The commenter states there are no local salmon eggs available. The Williamsburg Treaty was signed to prevent introduction of foreign eggs carrying known and unknown contagions not native to the region.

**Response #19** - The Williamsburg Resolution contains an exception allowing for import of eggs destined for land-based facilities wherein the risk of escape is minimal and for the import of that which is reproductively sterile. Representatives from the United States Fish and Wildlife Service and NOAA participate in risk assessments for escape and for pathogen introduction with importation. Below are excerpts from The Williamsburg Resolution (<http://www.nasco.int/pdf/agreements/williamsburg.pdf>), with language applicable to the application by Nordic italicized:

## 2. DESCRIPTION OF ZONES

Zone II: Geographic Area: Quebec rivers flowing into Gulf of St. Lawrence south of Pte. des Monts, GaspÉ region of Quebec, Magdalen Islands, Prince Edward Island, New Brunswick, Nova Scotia, Newfoundland (except rivers designated as Class I rivers, referenced above in description of Zone I) and *State of Maine east of Rockland*.

### 3.3 Protocols applicable to Zone II

#### 3.3.1 General within Zone II:

Reproductively viable non-indigenous species, other than Arctic char and brook trout, and reproductively viable Atlantic salmon stocks, non-indigenous to the NAC area, are not to be introduced into watersheds or into the marine environment of Zone II.

Restoration, enhancement and *aquaculture activities are permitted in the freshwater and marine environments*.

The Williamsburg Treaty further defines standards for aquaculture within Zone II:

### 3.3.4 Aquaculture

(i) Rearing in marine or freshwater cages, and land-based facilities:

- It is important to apply methods which minimize escapes;
- Reproductively viable Arctic char and brook trout may be reared in marine and freshwater cages and in land-based facilities;
- Develop domesticated salmon broodstock using local stocks; or, if local stocks are limited, use nearby stocks;
- *Reproductively viable non-indigenous species may only be introduced into land-based facilities where risk of escapement is minimal;*
- Non-indigenous salmonid stocks may be introduced into the wild or used in cage rearing operations if the fish are reproductively sterile and the risk of adverse ecological interactions is minimal.

In this instance, the risk of escape from Nordic's RAS facility is minimal, so the availability of or the lack of local salmon eggs is not relevant. The Board Order therefore remains unchanged.

**Comment #20 (UW)** - The initial draft order fails to address the issue that not all viral strains respond well to UV disinfection (e.g., the infectious pancreatic necrosis (IPN) virus) and that the turbidity in a waste stream negatively affects UV efficiency. UV systems can lose up to 40% of their initial efficiency in a year, so the UV light bulbs must be changed frequently. There is no plan for monitoring the efficacy of Nordic's UV system.

**Response #20** - Data for the effective dose of UV to neutralize various pathogens vary greatly. In large part, much of this variation is due to the log reduction in viral titre referenced by a particular study as being adequate for treatment of a particular pathogen. (In aquaculture, as it applies to disinfection, a one-log reduction refers to a 90% reduction, a two-log reduction to a 99% reduction, a three-log reduction to a 99.9% reduction, and a four log reduction to a 99.99% reduction.) Reported effective doses for the same log reduction can also vary significantly from study to study. Because small particles can function as a trojan horse for pathogens to bypass UV disinfection, the level of filtration examined from one study to the next can make a significant difference. In this respect, the Board finds that the ultra-fine level of solids filtration proposed by Nordic would make UV disinfection all the more effective. Acceptable doses for neutralization are often based on that which results in a two log to three log reduction. Such a reduction is acceptable for endemic pathogens but is inadequate by itself for exotic pathogens when there is an elevated risk of exotic pathogens being present. In this instance, however, sources that Nordic will be allowed to import by the MDMR will be of low risk for containing exotic pathogens. Nordic's UV disinfection plan provides sufficient mitigation for endemic pathogens. For example, for IPNV, a dose of 150 mJ/cm<sup>2</sup> is considered sufficient mitigation and Nordic proposes to use a 300 mJ/cm<sup>2</sup> dose of UV.

The Board agrees with the commenter that UV bulb strength decreases overtime and that bulbs need to be replaced regularly. The Board finds that the 300 mJ/cm<sup>2</sup> dose proposed by Nordic however, is more than sufficient to compensate for lost output between scheduled bulb replacements. From a compliance standpoint, there are many ways in which Nordic can ensure that the UV disinfection system is working properly. For example, industrial UV equipment contains built in sensors to monitor UV bulb output for the purposes of alerting operators to a problem. Scheduled bulb replacements according to manufacturer recommendations also avoid issues of insufficient UV dose. Specifications for sizing UV equipment are based on UV transmittance (water clarity) and output at the end of bulb life.

The table below shows UV doses required for a three-log reduction, except when noted as otherwise. Pathogens marked with an asterisk are those listed by MDMR as being of regulatory concern in Maine. The UV dose proposed by Nordic exceeds the highest levels cited for all pathogens listed below.

<u>Virus</u>	<u>Virus size (nanometers)</u>	<u>UV Dose (3 log reduction) mJ/cm<sup>2</sup></u>
<b><u>Non-Enveloped Viruses</u></b>		
<u>Birnaviridae</u>		
<u>IPNV*</u>	<u>65</u>	<u>118-246</u>
<u>Hepeviridae</u>		
<u>CTV, (family reference UV dose)</u>	<u>30</u>	<u>(22)</u>
<u>Nodaviridae</u>		
<u>VNNV*</u>	<u>25</u>	<u>104-211</u>
<u>Paramyxoviridae</u>		<u>11-30</u>
<b><u>Non-Enveloped Viruses</u></b>		
<u>Reoviridae</u>		
<u>PRV, Aquareoviruses</u>	<u>70-80</u>	<u>46-200</u>
<u>Totaviridae</u>		
<b><u>Enveloped Viruses</u></b>		
<u>Herpesviridae</u>	<u>125-250</u>	
<u>OMV*, SalHV-1, SalHV-4</u>	<u>200-250</u>	<u>2 log @2</u>
<u>Iridoviridae</u>	<u>130-330</u>	<u>26</u>
<u>Orthomyxoviridae</u>		
<u>ISAV*</u>	<u>100-130</u>	<u>8-51</u>
<u>IHNV*, VHSV*, SVCV*</u>	<u>65-90</u>	<u>4-20</u>
<u>Togaviridae</u>		<u>1 log est @ 44</u>

Bacterial pathogen such as Aeromonas salmonicida, Yersinia ruckeri, and Vibrio anguillarum require a UV dose of 5 to 25 mJ/cm<sup>2</sup> which is significantly lower than the 300 mJ/cm<sup>2</sup> dose Nordic will use at its facility.



The Board therefore finds that the UV treatment of the effluent as proposed is at a level to mitigate potential amplification of select endemic pathogens when the effluent is discharged in an area of greater potential for having contact with endangered Atlantic salmon. Following guidance provided by the Maine Aquatic Animal Health Technical Committee, MDMR expects a minimum UV dose of 30-50 mJ/cm<sup>2</sup>. In this regard, the dose to be used by Nordic plans to use is about 10 times greater than MDMR requires. Introduction and amplification of pathogens are prevented in numerous ways, including biosecurity protocols, influent treatment, health status of the source, quarantine testing, vaccination, and general fish welfare practices. The Board Order therefore remains unchanged.

**Comment #21 (UW)** - One must have at least two systems in serial as backup in case one of them fails. Prudence requires a non-UV backup system that relies on treatment with ozone and chlorine, for example. Ozone can only be used as an effective treatment technique with fresh water as its use on saltwater produces hypobromous acid (bromine gas in water) from the bromides that naturally occur in seawater. The use of chlorine as a treatment technique introduces the problem of trihalomethane production. That would be an undesirable outcome, from a water quality standpoint. However, backup treatment is still needed.

**Response #21** - Nordic has proposed what is essentially a redundant effluent treatment system. The Board Order finds the effluent filtration, at 0.04 um, is fine enough to retain all viruses of regulatory concern, while the subsequent proposed UV dose is at a three-log reduction or greater for all pathogens of regulatory concern.

With regard to the commenters concern about treatment with ozone, ozone will first oxidize organics before it converts bromide to bromine. Thus, very little bromine is formed when ozone is only used for improving water clarity. In most RAS facilities, ozone is used for improving water clarity by oxidizing organics, which makes UV disinfection more effective. Typical disinfection applications are for freshwater influent treatment and for quarantine effluent treatment of small volumes of fresh or saltwater. However, ozone is sometimes used at higher levels adequate for disinfection in which bromine formation is of concern. Because Nordic's proposed quarantine units may use ozone for disinfection under freshwater conditions in which bromide is not present, bromine formation is not a concern in this instance. The Board Order therefore remains unchanged.

**Comment #22 (UW)** - It will be very difficult to maintain the microbiota in a system that mixes or switches between fresh and saltwater as the microbes that thrive in those two conditions differ greatly. If separate systems for fresh and saltwater are used, then ozone treatment can be used on the freshwater flows. If the fresh and saltwater will be mixed together, Nordic must be required to assess and control the impact of antimicrobials on bioreactor efficiency.

**Response #22** - Land based RAS facilities avoid large salinity swings for this reason. Fish are generally transferred into higher salinity systems rather than changing the salinity within a system. Microbes of biofiltration can handle minor changes in salinity that occur slowly. The Board Order remains unchanged.

**Comment #23 (UW)** - In order to filter pathogenic bacteria from ocean water, one would need to filter that water through a 0.22 micrometer (um) filter, which would slow the pumping of the water and would likely clog easily. The residue cake from clogged filters will need to be characterized to determine if it is hazardous, solid, or medical waste. Nordic has not provided a plan for handling this waste. Parasites are difficult to control and cannot currently be vaccinated against. The use of anti-parasite drugs such as ivermectin is usually reserved for use after an outbreak is detected. Intervenors are concerned that antimicrobials used to address bacteria and parasites may be released into the environment and cause an increase in antimicrobial resistance in pathogens of both animals and humans. A concentration limit and associated monitoring must be required for antimicrobials.

**Response #23** - Ivermectin is not approved for use in food fish. Emamectin, a related compound which goes by the trade name Slice®, was used in the open ocean farming of salmon to control sea lice but has not been used in Maine in recent years. Because sea lice and their reproductive stages are much larger than other common parasites of salmon, they are easily removed from the water source with mechanical filtration. Furthermore, if introduced into one tank, the drum screen microfiltration of each RAS is suitable for subsequent removal. For this reason, sea lice are not able to rapidly spread from one tank to another in the same way they can in open net-pen aquaculture. Filtration capabilities on the intake and on each RAS, combined with other advantages of growing in tank-based systems, makes sea lice a very minor concern.

In contrast to sea lice, much smaller protozoan parasites which are ubiquitous to Maine waters are more likely to be introduced via momentary lapses in biosecurity and due to their prevalence, size, and tolerance to UV. However, most protozoans are relatively easy to manage with formalin, which, rather than Ivermectin, is the typical anti-parasite chemical of choice. When used in a flow thru system, most formalin is lost to discharge to the environment. However, formalin, when used in RAS such as Nordic's facility, is rapidly removed due to heterotrophic bacteria that use it as a carbon source in a nitrogen rich environment. Formalin, if used, will be rapidly degraded by the biofilters of each RAS and again by Nordic's effluent treatment system. When used in RAS such as Nordic's, which discharges formalin into an effluent treatment system, formalin discharge to the environment will likely be non-detectable even if it were to be used regularly and at the maximum levels allowed by the Department. Furthermore, its rapid breakdown in the presence of organics would result in non-detectable levels making it past the effluent treatment plant.

The use of antibiotics is regulated by FDA and the amount that can be used is limited according to their approved label for use. In this sense, the amount of antibiotics that could be used is already restricted. MDMR is authorized to require antibiotic use reporting through the authority provided in 12 M.R.S.A. §6085(5) (<http://legislature.maine.gov/statutes/12/title12sec6085.html>). The Board Order therefore remains unchanged.

## **Eelgrass**

**Comment #24 (HF)** – The initial draft permit fails to protect and restore vital eelgrass beds in Belfast Bay. Eelgrass is vital to supporting nursery habitat for seasonal and migrating fish and shellfish as well and for carbon sequestration. Nordic’s application identifies large areas of eelgrass that were viable as recently as 2019 at a critical distance to the effluent outfall pipe.

**Response #24** – The Board agrees that eelgrass is an important plant species in the marine ecosystem. In 2019, Department staff completed a survey of eelgrass distribution along portions of the Belfast and Northport shorelines in the project vicinity where eelgrass had previously been mapped as present during Maine Department of Marine Resources surveys. On Figure 1 in Attachment F of the draft order, yellow boxes indicate the areas that were surveyed in 2019. Of those areas, only the southern-most yellow box demonstrated eelgrass presence. (See also the small green polygon in the Fig. 5 focus area). This nearest mapped eelgrass to the proposed outfall location was approximately 2.5 miles to the south, which will not be impacted by the proposed discharge as modelled to date due to the proposed limits for nitrogen that are protective of dissolved oxygen and eelgrass. At this time, absent a more widespread eelgrass mapping program, the Board is not aware of eelgrass distribution beyond the bounds of the 2019 survey areas. Therefore, the Board Order remains unchanged.

## **Seasonally (May – October) monitor the effluent for total phosphorus, total ammonia, total kjeldahl nitrogen, nitrate + nitrite nitrogen;**

**Comment #25 (MGL)** - Nordic proposes to dump 7.7 million of gallons per day (MGD) of wastewater year-round that is 5° to 33° warmer than the ambient water temperatures and contains a multitude of known and unknown contaminants regardless of weather conditions. To put this in perspective, the initial draft order permits Nordic to dump more wastewater every day into Penobscot Bay than the entire community of Bayside is authorized to dump in the Bay in a year. Yet the initial draft order proposes to only monitor the effluent for some contaminants for only half of the year and does not require monitoring the heat of the discharged water although heat is a pollutant under the CWA and will decimate the lobster population. This limited seasonal monitoring of pollution is grossly inadequate and irresponsible.

**Response #25** – With regard to the commenter’s concerns about temperature, Special Condition A(1) *Effluent Limitations and Monitoring Requirements* of the draft order establishes a year-round daily maximum limit and year-round monitoring requirements for temperature. Based on information in the record, the Board finds the effluent plume should be positively buoyant due to the lower salinity and warmer temperature than the surrounding ambient water. The effluent should also have upward momentum upon discharge from the outfall diffuser. Both factors mean that the effluent will rise to a location in the water column above the benthic surface such that it will not come in contact with juvenile and adult lobsters. Although the Board finds the information in the record regarding temperature sufficient to satisfy licensing criteria, Special Condition F, Dye Study, of the Board Order requires a dye study to validate and confirm the

anticipated behavior of the effluent plume in the receiving water and gather further information. If the dye study shows the modeling results to date are not accurate, the Department may modify limitations and or require additional information/data be collected pursuant to Special Condition O, *Reopening The Permit For Modifications*, to confirm that water quality standards will be met in the receiving water.

With regards to the commenter's concerns about seasonal monitoring, seasonal monitoring (May-October) for nitrogen is appropriate because this is the period of greatest environmental sensitivity for the organisms that respond most readily to eutrophication, which are phytoplankton and macroalgae. Excess nitrogen in marine waters is most likely to instigate phytoplankton or macroalgae blooms when photoperiod is longest for daylight and when nutrients are in greatest demand. In the upper Bay, spring river flow will provide more nutrient-rich water but also increases water column mixing that makes phytoplankton proliferation more difficult. As river flow declines into summer and daylight is ample, ambient nutrients are used up quickly and phytoplankton are more likely to be stimulated by effluent nutrients. May-October is also a critical period for ambient monitoring where this is a critical period for settlement of larvae, and growth of and reproduction by marine organisms. Those organisms that have a benthic phase (or live or rely on the seafloor) at some time during May-October could be compromised by effluent loading that alters conditions above some local tipping point. MDMR samples for biotoxins in water and tissue from May-October due to this being the period of greatest potential for harmful algal blooms. In the Board's judgment, seasonal monitoring during this period is therefore appropriate to assess the time of greatest environmental sensitivity, while monitoring the other months of the year is not necessary. See Response #26. The Board Order therefore remains unchanged.

### **Ambient water quality monitoring**

**Comment #26 (MGL)** - A requirement to conduct only seasonal (May – October) ambient water quality monitoring at five (5) stations in Belfast Bay is grossly inadequate and without scientific justification. The lifecycles of fish on which fishermen depend continues in the other six months of the year. The Board has the responsibility to protect the water quality of the state throughout the year.

**Response #26**— See Response #25. The Department is aware that the lifecycles of marine life continue year-round. The draft order therefore establishes limitations and monitoring requirements on a year-round basis. Because certain parameters such as nitrogen, ammonia, phosphorus, and temperature have the potential to exert a higher level of impact on the receiving water in the warmer months of the year (May-October) rather than the colder months, the draft order requires seasonal limitations or monitoring requirements for these parameters as well as ambient water quality monitoring at five (5) designated sampling stations during this time frame. Establishing effluent limitations or monitoring requirements for these parameters between November and April is not necessary to make the finding that the proposed discharge will not cause or contribute to the failure of the receiving water to meet the standards of its assigned classification on a year-round basis. Therefore, the Board Order remains unchanged.

**Comment #27 (UW)** – The initial draft order contains no enforceable consequences if the findings of the required seasonal (May – October) ambient water quality monitoring at five (5) stations in Belfast Bay show that ambient water quality has been damaged by Nordic’s effluent. This after-the-fact monitoring is insufficient.

**Response #27** - If effluent monitoring results or ambient water monitoring results obtained from the five monitoring stations indicate the discharge from the proposed facility is causing or contributing to a non-attainment of water quality standards, the Department may modify limitations and require additional information/data be collected to confirm water quality standards are being met in the receiving water pursuant to Special Condition O, *Reopening The Permit For Modifications*. The Board Order therefore remains unchanged.

**Comment # 28 (HF)** – A discharge of 7.7 MGD results in a steady stream of nitrogen rich effluent into the receiving water. The tidal waters and bay currents, stratified by seasonal changes, carry a mix of algal spores that are recharged by the nitrogen and will bloom when activated by sunlight. These algal blooms will occur most noticeably along the shallow waters and beach areas of Northport, Belfast, Lincolnville and Islesboro. Beach areas near Camden and Rockport and Castine could also be affected.

**Response # 28** - Algal spores are part of the life cycles of many macroalgal species. Algal spore release, settlement and induction is affected by many abiotic and biotic factors, the most notable of which include photoperiod and temperature. Separately, phytoplankton can form cysts that germinate from surficial sediment based on similar environmental cues as for macroalgal spores. Any enhancement of algal, whether phytoplankton or macroalgae, abundance based on nutrient increases should be apparent from pre- to post-operation monitoring of Nordic’s effluent as long as sites are located strategically relative to direction and magnitude of effluent influence. The current monitoring (Special Condition G) and dye study (Special Condition F) should inform relocation or addition of ambient monitoring sites if sites previously chosen do not sufficiently capture effluent influence. If proliferating algae are situated along the shoreline where shellfish are harvested and/or people recreate, there will undoubtedly be a record of impacts should they occur. Further, the MDMR samples the water column for phytoplankton beyond the determined far field area (in Searsport and Lincolnville Beach) and will observe and report conspicuous water discoloration by plane. The Department may additionally consult with MDMR to determine if a shift in the phytoplankton community has occurred at nearby sites or if blooms have been observed.

The Department may take responsive actions to reduce nutrient loading from Nordic’s effluent if needed pursuant to Special Condition O, *Reopening The Permit For Modifications*. The Board Order remains unchanged.

## **Nitrogen**

**Comment #29 (UW, G&M)** - Nitrogen must be limited on a daily basis – not a monthly average.

**Response #29** – Total nitrogen load is limited on a daily basis (1,348 lbs/day) in the draft order. The constituents of total nitrogen are not, so any allocation of TKN vs. NO<sub>3</sub>+NO<sub>2</sub> is permissible as long as the total does not exceed the monthly average limit based for pounds per day (lbs/day). Because nitrogen does not function in an acute manner, the Board finds average conditions determined over a one-month period are sufficient to determine possible ambient impacts. The Board Order therefore remains unchanged.

**Comment #30 (NVC)** – The initial draft order contains concentration estimates of 21 mg/L and a loading of 1,348 pounds per day for total nitrogen. If these limits are included in the conditions of the draft order, they must be enforceable daily maximum limits of 21 mg/L and a pounds per maximum day limit for total nitrogen that is directly proportional to their discharge flow rate for that day ratioed to the ultimate daily maximum limit of 1,348 pound per day. Nordic must also demonstrate future compliance with this limit immediately upon start-up. Because Nordic has provided insufficient information to demonstrate that it can meet this newly proposed limit of 21 mg/L and because final discharge flows from the facility will not be established for ten or more years, it is unclear whether this facility can possibly meet the newly proposed limit. If Nordic cannot meet the 21 mg/L on a daily basis, then an anti-degradation hearing was required, the permit process will have been proven to be flawed, and the facility will need to be shut down immediately. The 21 mg/L must be a maximum daily limit in the conditions.

**Response #30** – The value of 21 mg/L in the calculations for nitrogen in this Fact Sheet is a licensing threshold by which a water quality-based effluent limitation (WQBEL) is calculated and is not a WQBEL in and of itself. Generally, concentration limitations established in permits are technology-based limits. Because there are currently no state or federally promulgated numeric BPT standards for nitrogen for land-based RAS facilities, the 21 mg/L is a site specific value calculated based on guidance contained in the state's antidegradation policy and utilizing ambient total nitrogen values obtained by Department staff for Belfast Bay. (Please see the discussion on page 22 through 24 of the Fact Sheet for more detail.) The value represents a discharge concentration at full permitted flow that will utilize no more than 20% of the remaining assimilative capacity of the receiving water. The value was in turn used to calculate an enforceable monthly average water quality-based mass limitation of 1,389 lbs/day for total nitrogen. The value of 21 mg/L was not intended to be nor should it be used to establish an end-of-pipe concentration limit. It would be inappropriate to establish a BPT monthly average or daily maximum concentration limitation based on a value from a water quality-based calculation. The draft order requires the permittee to report monthly average and daily maximum concentrations of total nitrogen. The Board Order therefore remains unchanged.

The commenter also states that the mass limitation of 1,389 pounds per day must be imposed as a daily maximum limitation. The primary purpose of the nitrogen limit is to prevent eutrophication related responses to the resource, which are typically associated with excessive algae growth (water column or benthic). These types of responses generally occur on a fairly broad and relatively systemic scale, because the biota have difficulty adapting and proliferating under dynamic conditions. The far field area associated with the discharge modeling is a very dynamic zone of initial influence/mixing, with significant variations of effluent concentrations throughout the far field area. Areas of higher concentration are relatively transient and do not persist to any significant spatial scale. Reasonably expected fluctuations in overall effluent quality would not be expected to have measurable influences on the broader scale. Therefore, the Board Order concludes it is not appropriate nor is it consistent with the Department's past practices to establish the water quality-based mass limitation as a daily maximum. See Response #30. The Board Order therefore remains unchanged.

### **Antidegradation**

**Comment #31 (MGL)** – The Board lacks the necessary information to make the statements on page 3 of the initial draft order as conclusions or findings. Nordic has not provided sufficient evidence to support these findings or conclusions and the limited information provided by Nordic contradicts them. Department staff has failed to have independent analysis done necessary to honestly make these findings or conclusions.

**Response #31** –The Findings and Conclusion section of the Board Order to which the commenter refers reflects general statutory criteria for approval of a new WDL/MEPDES permit and typically appears in Department issued discharge permits. Many of the antidegradation and other criteria are conditional (i.e., if-then statements). In this instance, however, the conditions triggering the need for certain further findings and conclusions do not exist. For example, based on record information, *see* pages 36 and 37 of the Fact Sheet, Nordic's proposed discharge, as permitted, will not "result in lowering the existing water quality of any waterbody," so the Board need not find, "following opportunity for public participation, that this action is necessary to achieve important economic or social benefits to the State." *See* 38 M.R.S. § 464(4)(F)(5). The Board's overall findings and conclusions that: (1) the discharge will not lower the quality of any classified body of water below its classification; (2) the discharge will not lower the quality of any unclassified body of water below its expected classification; (3) the provisions of the State's antidegradation policy will be met; and (4) the discharge will be subject to effluent limitations that require application of best practicable treatment remain unchanged from the initial draft order. Footnotes have been added to the Findings and Conclusions section, however, to clarify where conditions requiring certain further findings or conclusions do not exist.

Additionally, the Conclusions and Findings section of the draft board order was based on the independent analysis by the Department as described by parameter or subject matter in this Fact Sheet. The discharge as permitted incorporates BPT standards where appropriate, establishes water quality-based limitations in the absence of BPT standards, and requires further study or data collection to verify modeling results and compliance with standards associated with the Class SB water classification of Belfast Bay. The independent analysis was conducted in accordance with the state's antidegradation policy and the results show that the discharge, as permitted, will not cause or contribute to the lowering of water quality. Therefore, aside from clarifying footnotes, the Board Order remains unchanged.

**Comment #32 (UW)** – The proposed discharge limitations contained in NAF's MEPDES permit application are based on full production at the facility (Phase 2 levels). During its first years of operation (Phase 1), the facility will be operating at approximately 50% capacity and discharge limits should be adjusted accordingly. Otherwise, there is no incentive for Nordic to operate its controls at their designed efficiency levels.

**Response #32** – Standard Condition B(1)(a-c) of the permit states as follows:

- (a) The permittee shall collect all waste flows designated by the Department as requiring treatment and discharge them into an approved waste treatment facility in such a manner as to maximize removal of pollutants unless authorization to the contrary is obtained from the Department.
- (b) The permittee shall at all times maintain in good working order and operate at maximum efficiency all wastewater collection, treatment and/or control facilities.
- (c) All necessary waste treatment facilities will be installed and operational prior to the discharge of any wastewaters.

Standard Conditions requires the permittee to operate its controls at their designed efficiency levels at all times.

To address the commenter's concern that the facility could be operating for an extended period of time with the completion of Phase I only (50% of the full capacity of the production facility), the Board has revised Special Condition O, *Reopening The Permit For Modifications* to include the following:

Without limiting the foregoing paragraph, this permit may be reopened to establish revised effluent limitations, require additional monitoring of the effluent, ambient receiving water, or change monitoring requirements if the permittee fails to complete construction of Phase II of the facility within 30 months of the completion of the three grow out tanks for Phase I.



# **ATTACHMENT A**



TAKEN FROM U.S.G.S. 7.5 MINUTE BELFAST AND SEASPORT, MAINE-1976 (REVISED 1979).

CONTOUR INTERVAL IS 20 FEET

SITE COORDINATES: LATITUDE 44° 23'43.8"N  
LONGITUDE 68° 59'17.0"W

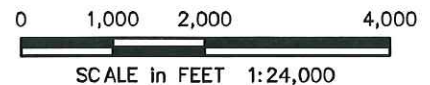

**RANSOM** Consulting Engineers and Scientists

*SITE LOCATION MAP*

PREPARED FOR:

NORDIC AQUAFARMS, INC.  
159 HIGH STREET  
PO BOX 283  
BELFAST, MAINE

SITE:

PROPOSED COMMERCIAL LAND-BASED  
AQUACULTURE FACILITY  
285 NORTHPORT AVENUE  
BELFAST, MAINE

PROJECT: 171.05027.008

FIGURE: 1







# **ATTACHMENT B**

EPA Form 2D - Question III.B. - Attachment 1

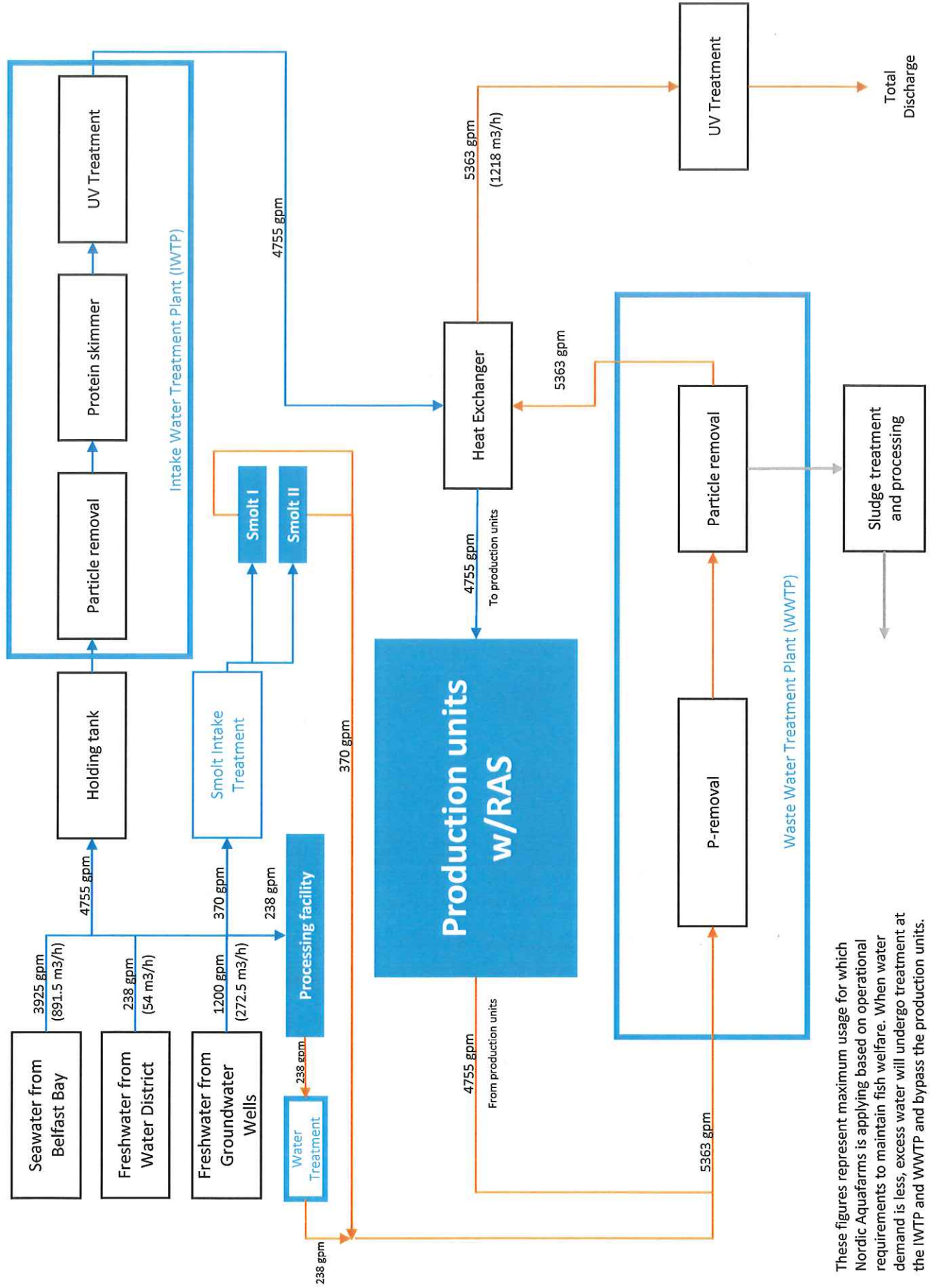

These figures represent maximum usage for which Nordic Aquafarms is applying based on operational requirements to maintain fish welfare. When water demand is less, excess water will undergo treatment at the IWTP and WWTP and bypass the production units.

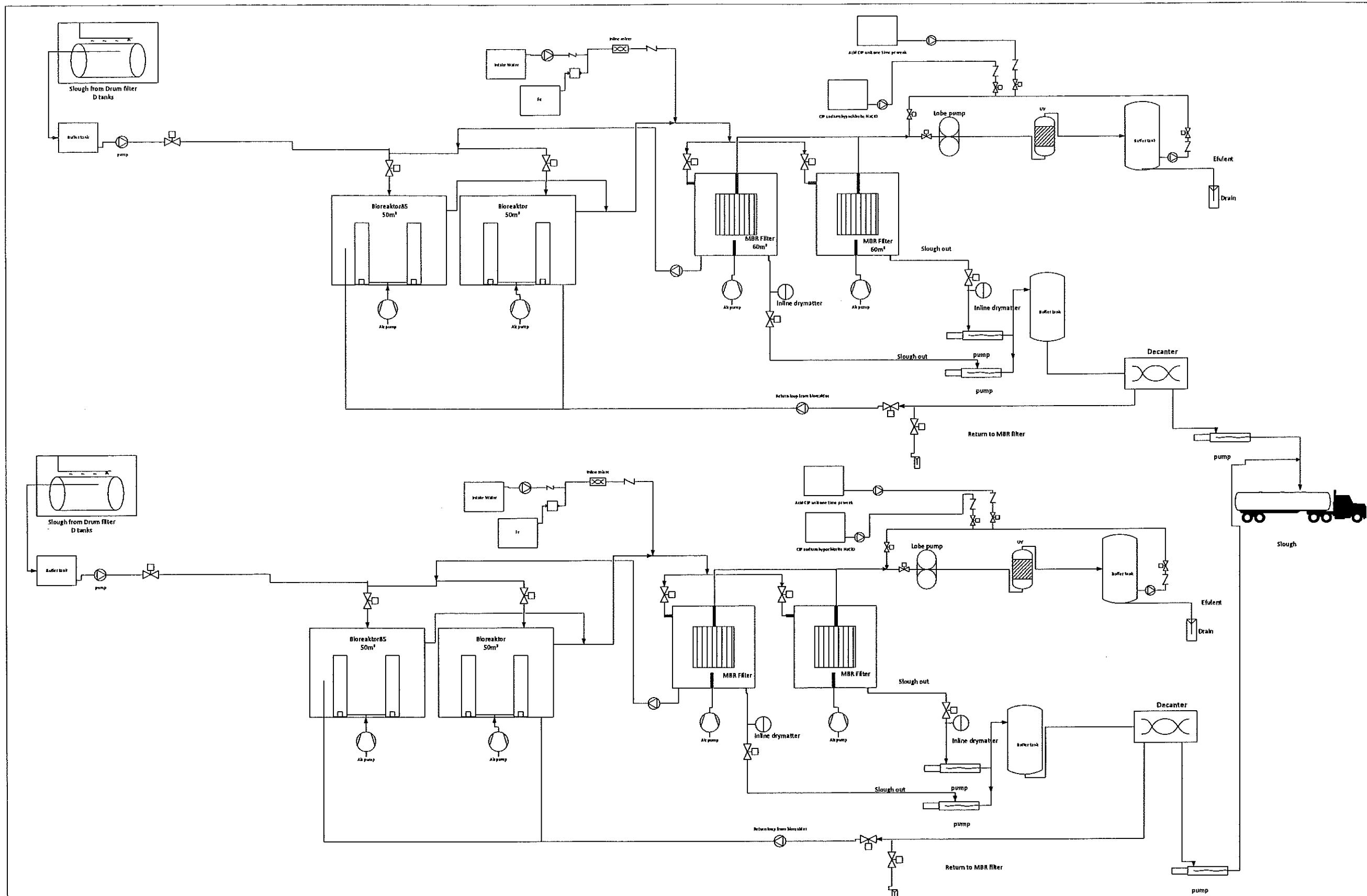

Project Information		Client Information	
Project Name	Wastewater Treatment Plant	Client Name	ABC Waterworks
Project No.	12345	Client Address	123 Main St, City, State
Design No.	67890	Client Contact	John Doe, Project Manager
Approval	Approved	Date	2023-10-27

# **ATTACHMENT C**

# Grow-Out Module Tank Layout

# Fish Rearing Facility Form Question # 9 Attachment 2

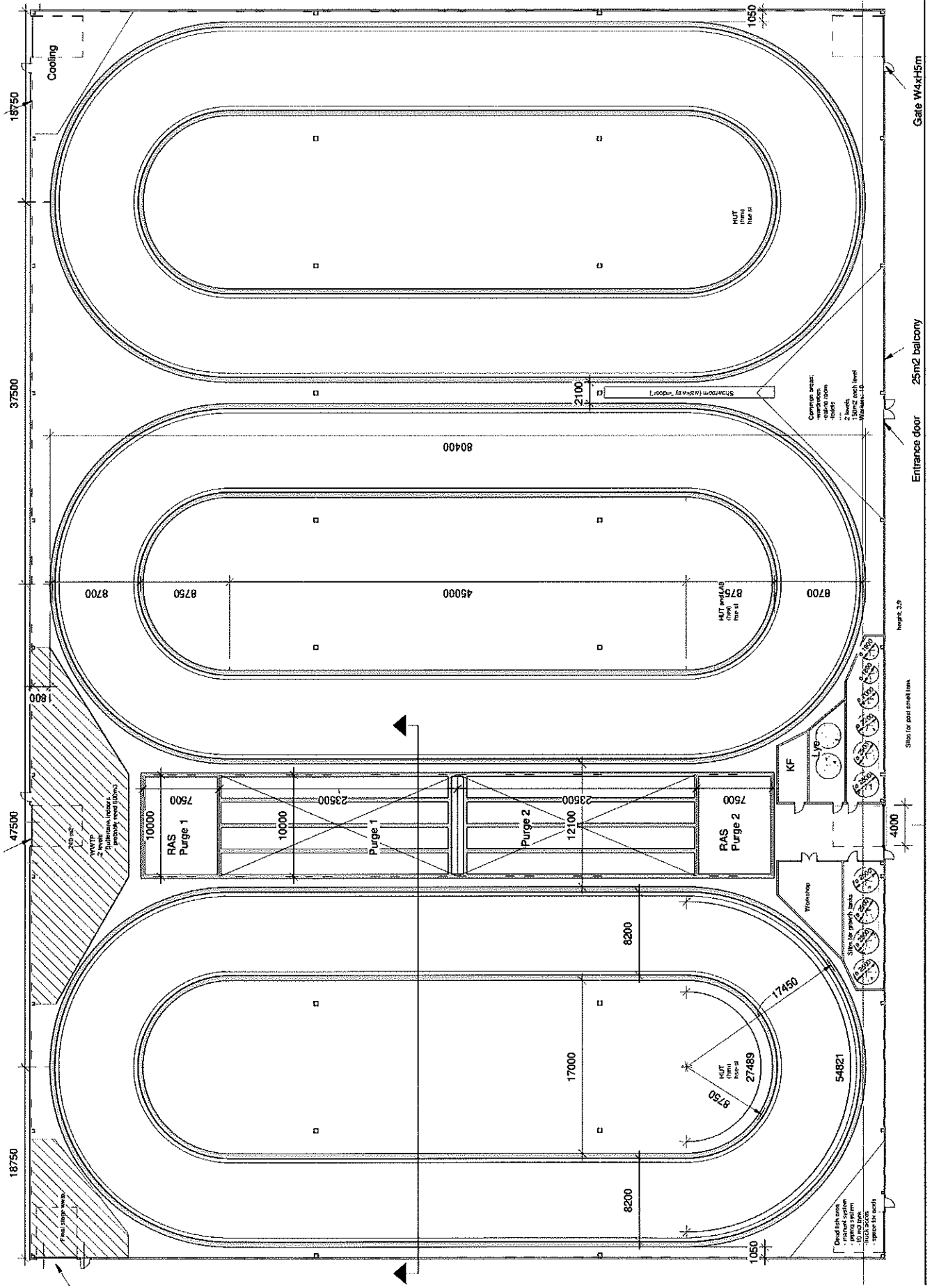



# Smolt Unit

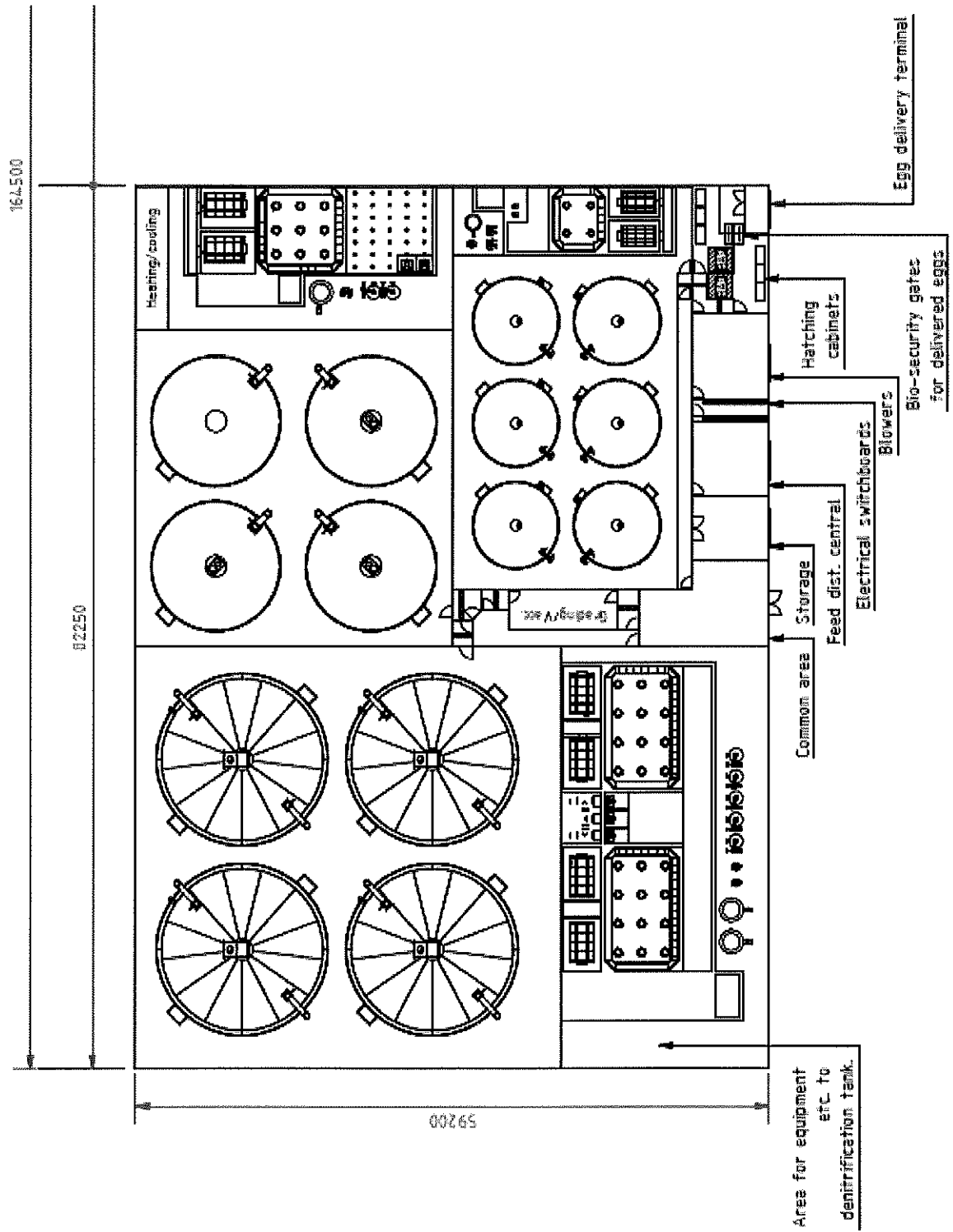

# **ATTACHMENT D**





# **ATTACHMENT E**





# Department of Marine Resources

Legal Notice of Shellfish Closure Area  
C 32 Belfast Bay, Belfast

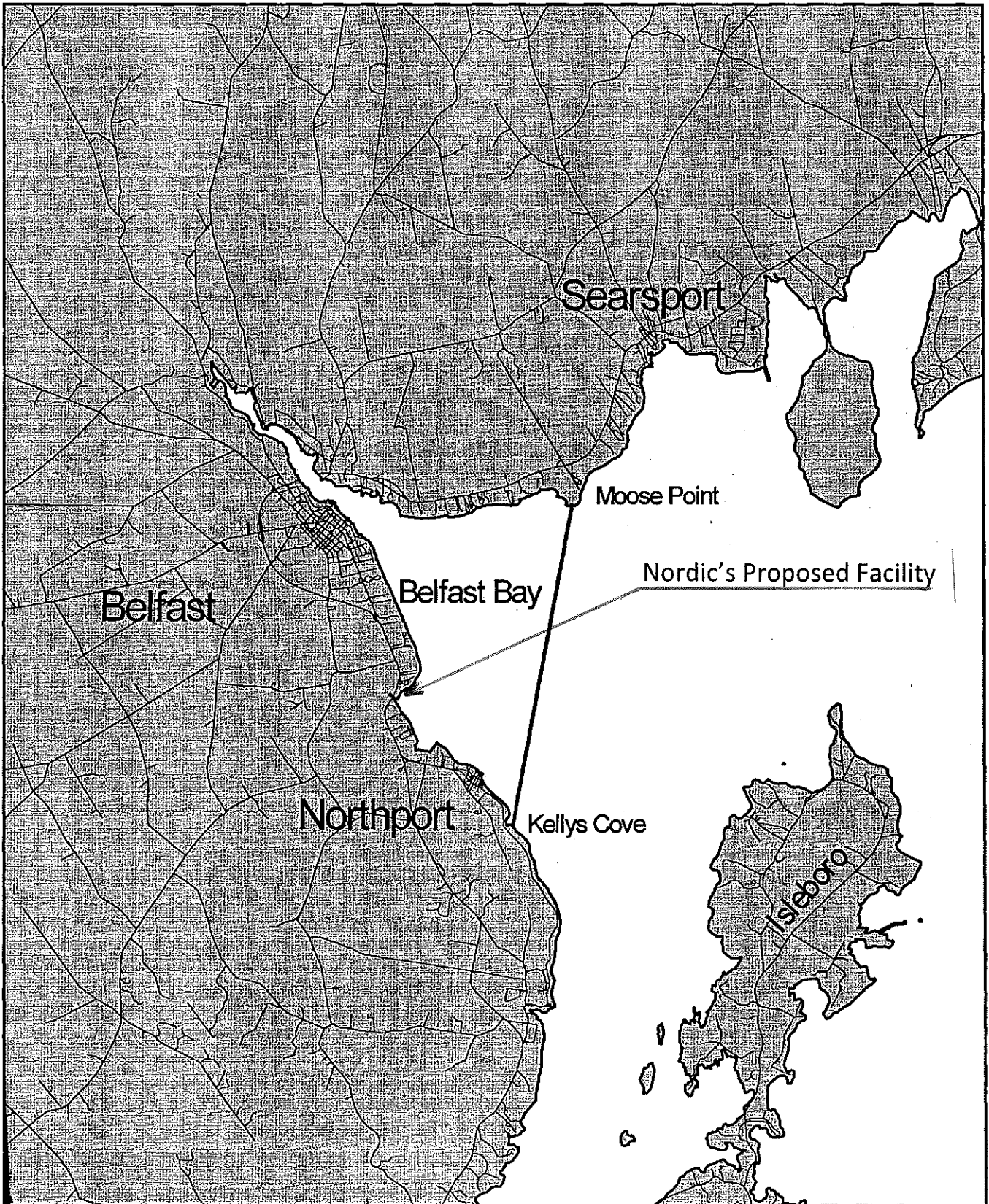

# **ATTACHMENT F**



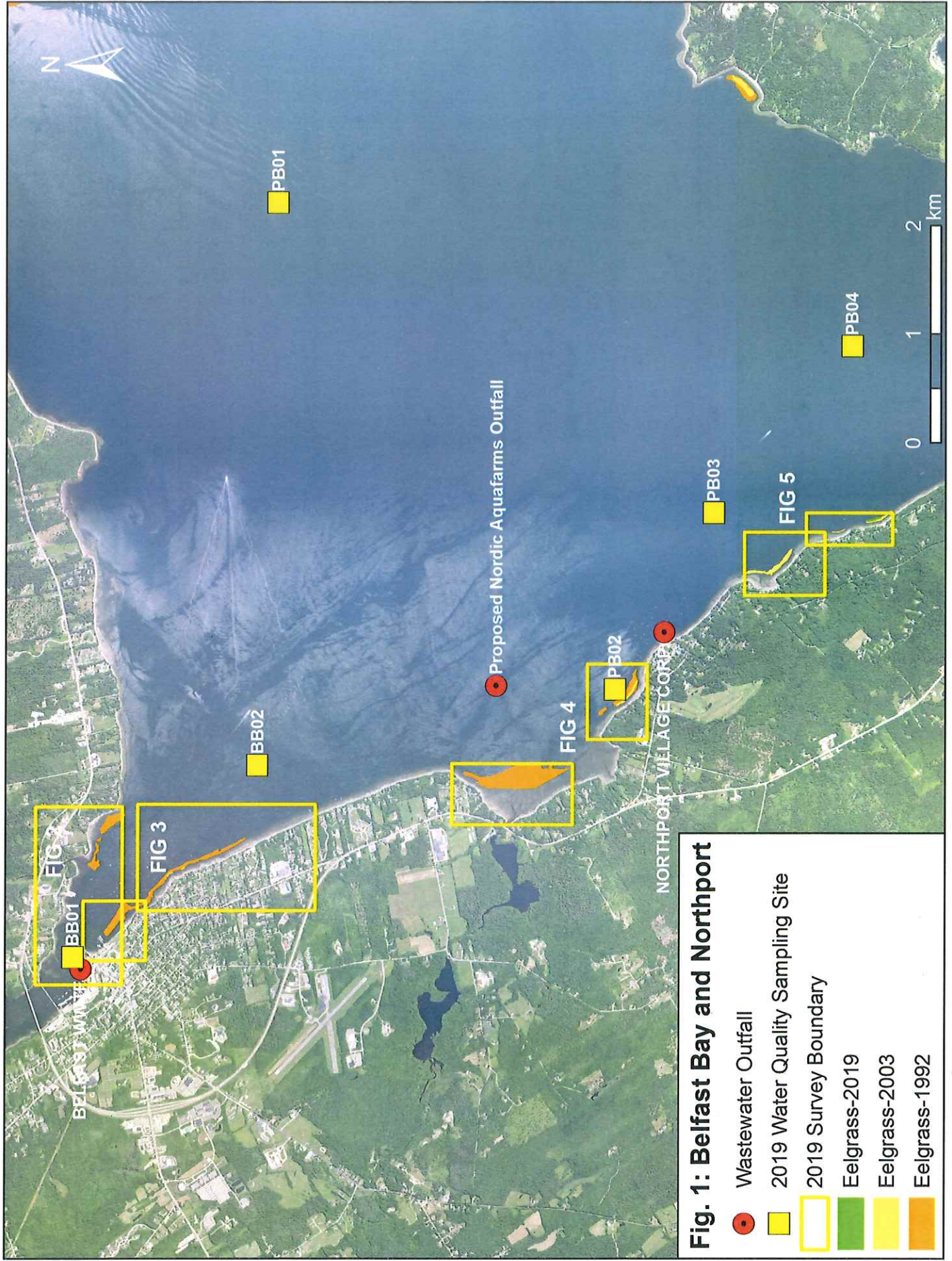

# **ATTACHMENT G**



STATE OF MAINE  
DEPARTMENT OF ENVIRONMENTAL PROTECTION

CHAPTER 530.2(D)(4) CERTIFICATION

MEPDES# \_\_\_\_\_ Facility Name \_\_\_\_\_

Since the effective date of your permit, have there been;		NO	YES Describe in comments section
1	Increases in the number, types, and flows of industrial, commercial, or domestic discharges to the facility that in the judgment of the Department may cause the receiving water to become toxic?	<input type="checkbox"/>	<input type="checkbox"/>
2	Changes in the condition or operations of the facility that may increase the toxicity of the discharge?	<input type="checkbox"/>	<input type="checkbox"/>
3	Changes in storm water collection or inflow/infiltration affecting the facility that may increase the toxicity of the discharge?	<input type="checkbox"/>	<input type="checkbox"/>
4	Increases in the type or volume of hauled wastes accepted by the facility?	<input type="checkbox"/>	<input type="checkbox"/>

COMMENTS:

Name (printed): \_\_\_\_\_

Signature: \_\_\_\_\_ Date: \_\_\_\_\_

**This document must be signed by the permittee or their legal representative.**

This form may be used to meet the requirements of Chapter 530.2(D)(4). This Chapter requires all dischargers having waived or reduced toxic testing to file a statement with the Department describing changes to the waste being contributed to their system as outlined above. As an alternative, the discharger may submit a signed letter containing the same information.

**Scheduled Toxicity Testing for the next calendar year**

Test Conducted	1 <sup>st</sup> Quarter	2 <sup>nd</sup> Quarter	3 <sup>rd</sup> Quarter	4 <sup>th</sup> Quarter
WET Testing	<input type="checkbox"/>	<input type="checkbox"/>	<input type="checkbox"/>	<input type="checkbox"/>
Priority Pollutant Testing	<input type="checkbox"/>	<input type="checkbox"/>	<input type="checkbox"/>	<input type="checkbox"/>
Analytical Chemistry	<input type="checkbox"/>	<input type="checkbox"/>	<input type="checkbox"/>	<input type="checkbox"/>
Other toxic parameters <sup>1</sup>	<input type="checkbox"/>	<input type="checkbox"/>	<input type="checkbox"/>	<input type="checkbox"/>

*Please place an "X" in each of the boxes that apply to when you will be conducting any one of the three test types during the next calendar year.*

<sup>1</sup> This only applies to parameters where testing is required at a rate less frequently than quarterly.



# DEP INFORMATION SHEET

## Appealing a Department Licensing Decision

**Dated: November 2018**

**Contact: (207) 287-2452**

### **SUMMARY**

There are two methods available to an aggrieved person seeking to appeal a licensing decision made by the Department of Environmental Protection's (DEP) Commissioner: (1) an administrative process before the Board of Environmental Protection (Board); or (2) a judicial process before Maine's Superior Court. An aggrieved person seeking review of a licensing decision over which the Board had original jurisdiction may seek judicial review in Maine's Superior Court.

A judicial appeal of final action by the Commissioner or the Board regarding an application for an expedited wind energy development (35-A M.R.S. § 3451(4)) or a general permit for an offshore wind energy demonstration project (38 M.R.S. § 480-HH(1)) or a general permit for a tidal energy demonstration project (38 M.R.S. § 636-A) must be taken to the Supreme Judicial Court sitting as the Law Court.

This information sheet, in conjunction with a review of the statutory and regulatory provisions referred to herein, can help a person to understand his or her rights and obligations in filing an administrative or judicial appeal.

### **I. ADMINISTRATIVE APPEALS TO THE BOARD**

#### **LEGAL REFERENCES**

The laws concerning the DEP's *Organization and Powers*, 38 M.R.S. §§ 341-D(4) & 346; the *Maine Administrative Procedure Act*, 5 M.R.S. § 11001; and the DEP's *Rules Concerning the Processing of Applications and Other Administrative Matters* ("Chapter 2"), 06-096 C.M.R. ch. 2.

#### **DEADLINE TO SUBMIT AN APPEAL TO THE BOARD**

The Board must receive a written appeal within 30 days of the date on which the Commissioner's decision was filed with the Board. Appeals filed more than 30 calendar days after the date on which the Commissioner's decision was filed with the Board will be dismissed unless notice of the Commissioner's license decision was required to be given to the person filing an appeal (appellant) and the notice was not given as required.

#### **HOW TO SUBMIT AN APPEAL TO THE BOARD**

Signed original appeal documents must be sent to: Chair, Board of Environmental Protection, 17 State House Station, Augusta, ME 04333-0017. An appeal may be submitted by fax or e-mail if it contains a scanned original signature. It is recommended that a faxed or e-mailed appeal be followed by the submittal of mailed original paper documents. The complete appeal, including any attachments, must be received at DEP's offices in Augusta on or before 5:00 PM on the due date; materials received after 5:00 pm are not considered received until the following day. The risk of material not being received in a timely manner is on the sender, regardless of the method used. The appellant must also send a copy of the appeal documents to the Commissioner of the DEP; the applicant (if the appellant is not the applicant in the license proceeding at issue); and if a hearing was held on the application, any intervenor in that hearing process. All of the information listed in the next section of this information sheet must be submitted at the time the appeal is filed.

### **INFORMATION APPEAL PAPERWORK MUST CONTAIN**

Appeal materials must contain the following information at the time the appeal is submitted:

1. *Aggrieved Status.* The appeal must explain how the appellant has standing to maintain an appeal. This requires an explanation of how the appellant may suffer a particularized injury as a result of the Commissioner's decision.
2. *The findings, conclusions, or conditions objected to or believed to be in error.* The appeal must identify the specific findings of fact, conclusions regarding compliance with the law, license conditions, or other aspects of the written license decision or of the license review process that the appellant objects to or believes to be in error.
3. *The basis of the objections or challenge.* For the objections identified in Item #2, the appeal must state why the appellant believes that the license decision is incorrect and should be modified or reversed. If possible, the appeal should cite specific evidence in the record or specific licensing requirements that the appellant believes were not properly considered or fully addressed.
4. *The remedy sought.* This can range from reversal of the Commissioner's decision on the license or permit to changes in specific permit conditions.
5. *All the matters to be contested.* The Board will limit its consideration to those matters specifically raised in the written notice of appeal.
6. *Request for hearing.* If the appellant wishes the Board to hold a public hearing on the appeal, a request for public hearing must be filed as part of the notice of appeal, and must include an offer of proof in accordance with Chapter 2. The Board will hear the arguments in favor of and in opposition to a hearing on the appeal and the presentations on the merits of an appeal at a regularly scheduled meeting. If the Board decides to hold a public hearing on an appeal, that hearing will then be scheduled for a later date.
7. *New or additional evidence to be offered.* If an appellant wants to provide evidence not previously provided to DEP staff during the DEP's review of the application, the request and the proposed evidence must be submitted with the appeal. The Board may allow new or additional evidence, referred to as supplemental evidence, to be considered in an appeal only under very limited circumstances. The proposed evidence must be relevant and material, and (a) the person seeking to add information to the record must show due diligence in bringing the evidence to the DEP's attention at the earliest possible time in the licensing process; or (b) the evidence itself must be newly discovered and therefore unable to have been presented earlier in the process. Specific requirements for supplemental evidence are found in Chapter 2 § 24.

### **OTHER CONSIDERATIONS IN APPEALING A DECISION TO THE BOARD**

1. *Be familiar with all relevant material in the DEP record.* A license application file is public information, subject to any applicable statutory exceptions, and is made easily accessible by the DEP. Upon request, the DEP will make application materials available during normal working hours, provide space to review the file, and provide an opportunity for photocopying materials. There is a charge for copies or copying services.
2. *Be familiar with the regulations and laws under which the application was processed, and the procedural rules governing your appeal.* DEP staff will provide this information on request and answer general questions regarding the appeal process.
3. *The filing of an appeal does not operate as a stay to any decision.* If a license has been granted and it has been appealed, the license normally remains in effect pending the processing of the appeal. Unless a stay of the decision is requested and granted, a license holder may proceed with a project pending the outcome of an appeal, but the license holder runs the risk of the decision being reversed or modified as a result of the appeal.

## **WHAT TO EXPECT ONCE YOU FILE A TIMELY APPEAL WITH THE BOARD**

The Board will formally acknowledge receipt of an appeal, and will provide the name of the DEP project manager assigned to the specific appeal. The notice of appeal, any materials accepted by the Board Chair as supplementary evidence, any materials submitted in response to the appeal, and relevant excerpts from the DEP's application review file will be sent to Board members with a recommended decision from DEP staff. The appellant, the license holder if different from the appellant, and any interested persons are notified in advance of the date set for Board consideration of an appeal or request for public hearing. The appellant and the license holder will have an opportunity to address the Board at the Board meeting. With or without holding a public hearing, the Board may affirm, amend, or reverse a Commissioner decision or remand the matter to the Commissioner for further proceedings. The Board will notify the appellant, the license holder, and interested persons of its decision.

## **II. JUDICIAL APPEALS**

Maine law generally allows aggrieved persons to appeal final Commissioner or Board licensing decisions to Maine's Superior Court (see 38 M.R.S. § 346(1); 06-096 C.M.R. ch. 2; 5 M.R.S. § 11001; and M.R. Civ. P. 80C). A party's appeal must be filed with the Superior Court within 30 days of receipt of notice of the Board's or the Commissioner's decision. For any other person, an appeal must be filed within 40 days of the date the decision was rendered. An appeal to court of a license decision regarding an expedited wind energy development, a general permit for an offshore wind energy demonstration project, or a general permit for a tidal energy demonstration project may only be taken directly to the Maine Supreme Judicial Court. See 38 M.R.S. § 346(4).

Maine's Administrative Procedure Act, DEP statutes governing a particular matter, and the Maine Rules of Civil Procedure must be consulted for the substantive and procedural details applicable to judicial appeals.

## **ADDITIONAL INFORMATION**

If you have questions or need additional information on the appeal process, for administrative appeals contact the Board's Executive Analyst at (207) 287-2452, or for judicial appeals contact the court clerk's office in which your appeal will be filed.

---

**Note: The DEP provides this INFORMATION SHEET for general guidance only; it is not intended for use as a legal reference. Maine law governs an appellant's rights.**

---

**Board of Environmental Protection**  
**Nordic Aquafarms, Inc. / Site Law, NRPA, MEPDES/WDL, and Air Applications**  
**Service List rev. September 1, 2020**

---

**Official Copy for Filings by 5:00 pm  
to Robert Duchesne, Presiding  
Officer c/o Ruth Ann Burke**

Robert Duchesne, Presiding Officer  
Board of Environmental Protection  
c/o Ruth Ann Burke  
17 State House Station  
Augusta, ME 04333-0017  
Phone (207) 287-2811  
Fax (207) 287-2814  
[Ruth.a.burke@maine.gov](mailto:Ruth.a.burke@maine.gov)

**[BEP]**

Cynthia Bertocci, Executive Analyst  
Board of Environmental Protection  
17 State House Station  
Augusta, ME 04333  
Phone (207) 287-2452  
[Cynthia.s.bertocci@maine.gov](mailto:Cynthia.s.bertocci@maine.gov)

**[Assistant Attorneys General]**

Office of the Attorney General  
6 State House Station  
Augusta, ME 04333-0006  
Fax (207) 626-8812

Peggy Bensinger  
Phone (207) 626-8578  
[Peggy.bensinger@maine.gov](mailto:Peggy.bensinger@maine.gov)

Scott Boak  
Phone (207) 626-8566  
[Scott.boak@maine.gov](mailto:Scott.boak@maine.gov)

Laura Jensen  
Phone (207) 626-8868  
[Laura.jensen@maine.gov](mailto:Laura.jensen@maine.gov)

**[DEP–With the exception of Gregg  
Wood, all correspondence to the  
postal and/or email address below]**

Dept of Environmental Protection  
17 State House Station  
Augusta, ME 04333-0017  
[NordicAquaFarms.DEP@maine.gov](mailto:NordicAquaFarms.DEP@maine.gov)

Nicholas Livesay, Director  
Bureau of Land Resources  
Phone (207) 530-0965

Beth Callahan, Project Manager  
Bureau of Land Resources  
Phone (207) 446-1586

Dawn Hallowell, Licensing and  
Compliance Manager  
Bureau of Land Resources  
Phone (207) 597-2624

Brian Kavanah, Director  
Bureau of Water Quality  
Phone (207) 287-7700

Gregg Wood, Director  
Division of Water Quality Management  
Bureau of Water Quality  
Phone (207) 287-7693  
Email: [Gregg.Wood@maine.gov](mailto:Gregg.Wood@maine.gov)

Cindy L. Dionne, Project Manager  
Bureau of Water Quality  
Phone (207) 287-7823

Jeff Crawford, Director  
Bureau of Air Quality  
Phone (207) 287-7647

Jane Gilbert, Air Licensing Unit Manager  
Bureau of Air Quality  
Phone (207) 287-2455

Patric Sherman, Project Manager  
Bureau of Air Quality  
Phone (207) 287-7645

Kevin Martin  
Compliance and Procedures Specialist  
Office of the Commissioner  
Phone (207) 287-4305  
[Kevin.martin@maine.gov](mailto:Kevin.martin@maine.gov)

Kevin Ostrowski, Senior Meteorologist  
Bureau of Air Quality  
Phone (207) 287-2424  
[Kevin.ostrowski@maine.gov](mailto:Kevin.ostrowski@maine.gov)

Angela Brewer, Biologist  
Bureau of Water Quality  
Phone (207) 592-2352  
[Angela.d.brewer@maine.gov](mailto:Angela.d.brewer@maine.gov)

**[Federal Agencies]**

Peter Tischbein  
US Army Corps of Engineers  
442 Civic Center Drive, Suite 350  
Augusta, ME 04330  
Phone (207) 623-8367  
[Peter.tischbein@usace.army.mil](mailto:Peter.tischbein@usace.army.mil)

**[Applicant – Nordic Aquafarms, Inc.]**

Erik Heim (email only)  
[Erik.heim@nordicaquafarms.com](mailto:Erik.heim@nordicaquafarms.com)

Marianne Naess (email only)  
[mn@nordicaquafarms.com](mailto:mn@nordicaquafarms.com)

Ed Cotter (email only)  
[ec@nordicaquafarms.com](mailto:ec@nordicaquafarms.com)

Jacki Cassida (email only)  
[jc@nordicaquafarms.com](mailto:jc@nordicaquafarms.com)

Joanna B. Tourangeau  
Drummond Woodsum  
84 Marginal Way, Suite 600  
Portland, ME 04101-2480  
Phone (207) 772-1941  
FAX (207) 772-3627  
[jtouangeau@dwmlaw.com](mailto:jtouangeau@dwmlaw.com)

Elizabeth Ransom  
Ransom Consulting, Inc.  
400 Commercial Street, Suite 404  
Portland, ME 04101  
Phone (207) 772-2891  
[Elizabeth.ransom@ransomenv.com](mailto:Elizabeth.ransom@ransomenv.com)

**[Intervenors]**

**Maine Lobstering Union, Wayne Canning, and David Black**

Kim Ervin Tucker  
48 Harbour Pointe Drive  
Lincolntonville, ME 04849  
Phone (202) 841-5439  
[k.ervintucker@gmail.com](mailto:k.ervintucker@gmail.com)

**Jeffrey R. Mabee and Judith B. Grace**  
[k.ervintucker@gmail.com](mailto:k.ervintucker@gmail.com)

**Upstream Watch**

David Perkins, Esq.  
Curtis Thaxter  
One Canal Plaza, Suite 1000  
Portland, ME 04101  
Phone (207) 774-9000  
[DPerkins@curtisthaxter.com](mailto:DPerkins@curtisthaxter.com)

**Eleanor Daniels**  
**Donna Broderick**  
95 Sirota Drive  
Searsmont, ME 04973  
Phone (207) 322-6464  
[ellie@greenstore.com](mailto:ellie@greenstore.com)  
[dl\\_broderick@hotmail.com](mailto:dl_broderick@hotmail.com)

**Northport Village Corporation**

Michael T. Lannan  
Tech Environmental  
Phone (207) 323-4850  
[mLannan@TechEnv.com](mailto:mLannan@TechEnv.com)

Northport Village Corporation  
813 Shore Road  
Northport, ME 04849  
Phone (207) 338-0751  
[nvcmaine@gmail.com](mailto:nvcmaine@gmail.com)

**University of New England**

Barry A. Costa-Pierce  
11 Hills Beach Road  
Biddeford, ME 04005  
[bcostapierce@une.edu](mailto:bcostapierce@une.edu)

**University of New England (cont.)**

Charles Tilberg  
11 Hills Beach Road  
Biddeford, ME 04005  
[ctilburg@une.edu](mailto:ctilburg@une.edu)

Carrie Byron  
11 Hills Beach Road  
Biddeford, ME 04005  
[cbryon@une.edu](mailto:cbryon@une.edu)

**Gulf of Maine Research Institute**

Donald W. Perkins, Jr.  
350 Commercial Street  
Portland, ME 04101  
[don@gmri.org](mailto:don@gmri.org)

**The Fish Are Okay**

Diane Hunt Braybrook  
1 Delemos Street  
Belfast, ME 04915  
Phone (207) 930-5979  
[dbraybrook@yahoo.com](mailto:dbraybrook@yahoo.com)

**Lawrence Reichard**

[lreichard@gmail.com](mailto:lreichard@gmail.com)